

Morgana DocuMaster



DOCUMENT CREASING & AUTOMATIC BOOKLET MAKING MACHINE

OPERATORS MANUAL (Part 1) **(Creasing Unit)**

Morgana Systems Limited United Kingdom
Telephone: (01908) 608888 Facsimile: (01908) 692399
Website: www.morgana.co.uk

ISSUE 7 SEPTEMBER 2007

FROM SERIAL No. 780046JFAB ONWARDS.

70-060

INTRODUCTION	
The Morgana Documaster	PAGE 4
THE CREASING UNIT	
Labelled Photograph	5
SAFETY Do's & Don'ts	6
THE CONTROL PANEL	
Detailed diagram and description	8
Features on the control panel	9
SETTING THE MACHINE UP AS A BOOKLET MAKER	
Setting the number of sheets in the Booklet	11
Setting the creasing style	11
Setting the crease position	11
Setting the cover creases	11
Setting the hinge positions	12
Setting the Pulse Feed or Stream Feed	12
Storing the Program	12
Running the machine	12
Reading stored Programs	12
Clearing Booklet sheets from the Booklet Maker Infeed Tray	12
Using the Booklet Maker in Manual Mode	13
SETTING THE MACHINE UP AS A CREASER	
Setting the crease positions	14
Storing the crease positions	14
Running the machine	15
Setting the Batch quantity	15
Setting the Pulse Feed or Stream Feed	15
Reading stored Programs	16
Clearing a stored program within the memory address	16
Paper Jamming	16
Setting the machine to operate in manual mode	16
QUICK START GUIDE	
Setting the machine to operate in automatic mode	17

OPERATING THE CREASER	
Setting the machine	PAGE 18
Adjusting the Paper Gate	18
Setting the Suction Slot	18
Setting the Adjustable Side Lay	19
Setting the Back Stop	19
Setting the Air Distribution	19
Setting the Air Separation Pressure	19
Setting the Roller Tilt Mechanism	19
Setting the Positions of Drive Wheels and Hubs	19
Setting the Extension Table	20
Setting the Measurement System - Inch / Metric	21
THE STACKER ASSEMBLY	
Setting the Stacker unit	22
PERFORATING	
Equipment, spares	24
Setting the machine	25
THE BLADE ASSEMBLY	
Setting the blade pressure	27
Setting the blade alignment	27
REPLACING CREASING BLADE SETS	
Installing new blade sets	29
Spares	30
TROUBLE SHOOTING	31
ERROR MESSAGES	34
DISPATCH KIT	35
ACCESSORIES AND OPTIONS	36
RECOMMENDED SPARES	37

Morgana DocuMaster

The Morgana DocuMaster is a fully automatic, suction feeding, creasing / booklet making system; designed for use with both conventional litho and digital printers.

IMPORTANT the operating environment should be controlled to a temperature between 16° C and 27° C Maximum.

The system comprises a creasing unit linked to a fully automatic booklet making machine, the creasing unit and booklet maker can be used separately to give optimum flexibility.

The feed system incorporates an ultrasonic detector system to ensure complete booklet integrity.

The feed on the Documaster can also be manually operated for use with heavy stock, very small or very large sheets, embossed or even irregular sheets.

The creasing unit is capable of creasing sheet sizes to a maximum of 999.9mm (39.4") x 330mm (13") and weights in excess of 350gsm.

When feeding book sets the difference between cover stock and inner leaves should not exceed 100gsm

The minimum sheet size when the machine is used in automatic mode is 140mm x 210mm (5½ "x 8½").

In the creasing mode Up to nine creases can be programmed to a single sheet.

The crease is programmed from the leading edge of the sheet using the controls on the front panel.

A minimum distance between creases is 3mm and it is possible to make micro adjustments to 0.1mm.

The Creaser has up to nine available memory addresses for programmed operations.

The blade and anvil are mechanically controlled over their entire length and can be adjusted to accommodate various weights of media.

Morgana DocuMaster

THE CREASING UNIT

Key to photograph below

- | | | | | | |
|---|-----------------------|----|---------------------|----|---------------------|
| 1 | Roller tilt handle | 7 | Adjustable side lay | 14 | Plinth |
| 2 | Stacker assembly | 8 | Back stop | 15 | Display |
| 3 | Suction slot knob | 9 | Fixed side lay | 16 | Anti-Static Unit |
| 4 | The control panel | 10 | Roller tilt knob | 17 | Alignment Handwheel |
| 5 | Air separation knob | 11 | Paper Gate | | |
| 6 | Air distribution knob | 12 | Exit Guard | | |

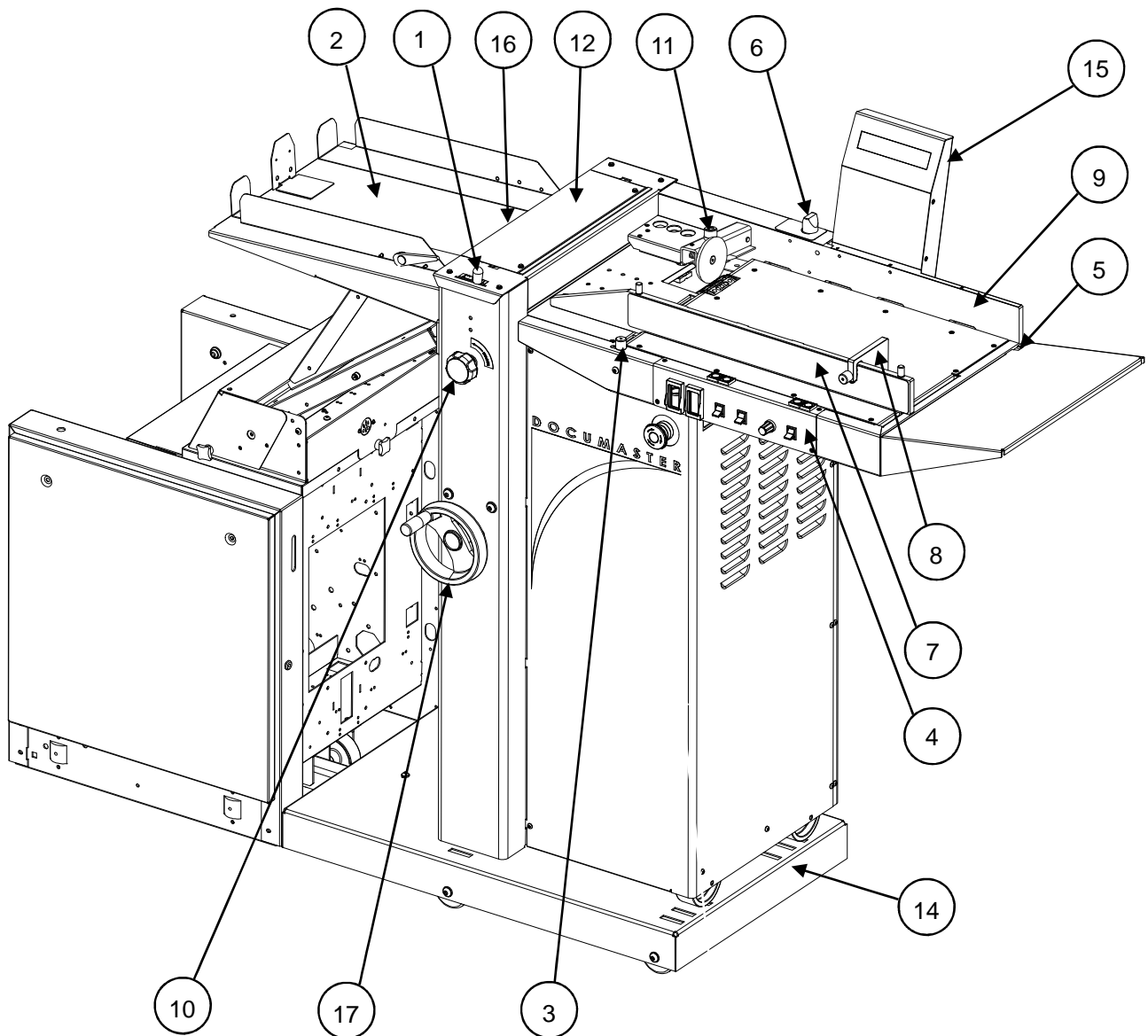

Safety Do's & Don'ts

- Do - read this operator manual fully before operating the machine.**
- Do - operate with the designated AC current only. Use an exclusive outlet, as overloading may cause fire or an electric shock.**
- Do - install the power cord out of the way to avoid a tripping hazard.**
- Do - beware of finger traps when replacing roller cassette and fold plates.**

- Do not - install the machine in an unstable place such that it tilts or shakes.**
- Do not - unplug the plug or unplug the power cord from the outlet with a wet hand, this can cause an electric shock.**
- Do not - unscrew and remove any covers from the machine, as it can cause an electric shock or injury.**
- Do not - place receptacles containing liquids on any surface.**
- Do not - adjust any part of the machine whilst rollers are running**
- Do not - operate the machine with loose or trailing clothing or loose hair.**
- Do not - under any circumstances adjust the paper gate when the machine is switched on.**

BLANK
PAGE

The Control Panel on the creasing unit allows the operator to read, edit, create and initiate numerous creasing and booklet making programs within the memory.

The top face of the control panel houses the four push buttons as shown in the diagram below. For the purposes of the instructions these buttons will be described as **Push Buttons 1, 2, 3, 4.**

The front face of the control panel houses the Compressor switch, System switch, Feed switch, Suction switch, Setting dial and Set-up switch. Under the control panel is an industry standard Emergency Stop switch which will stop all power going to the machine when activated.

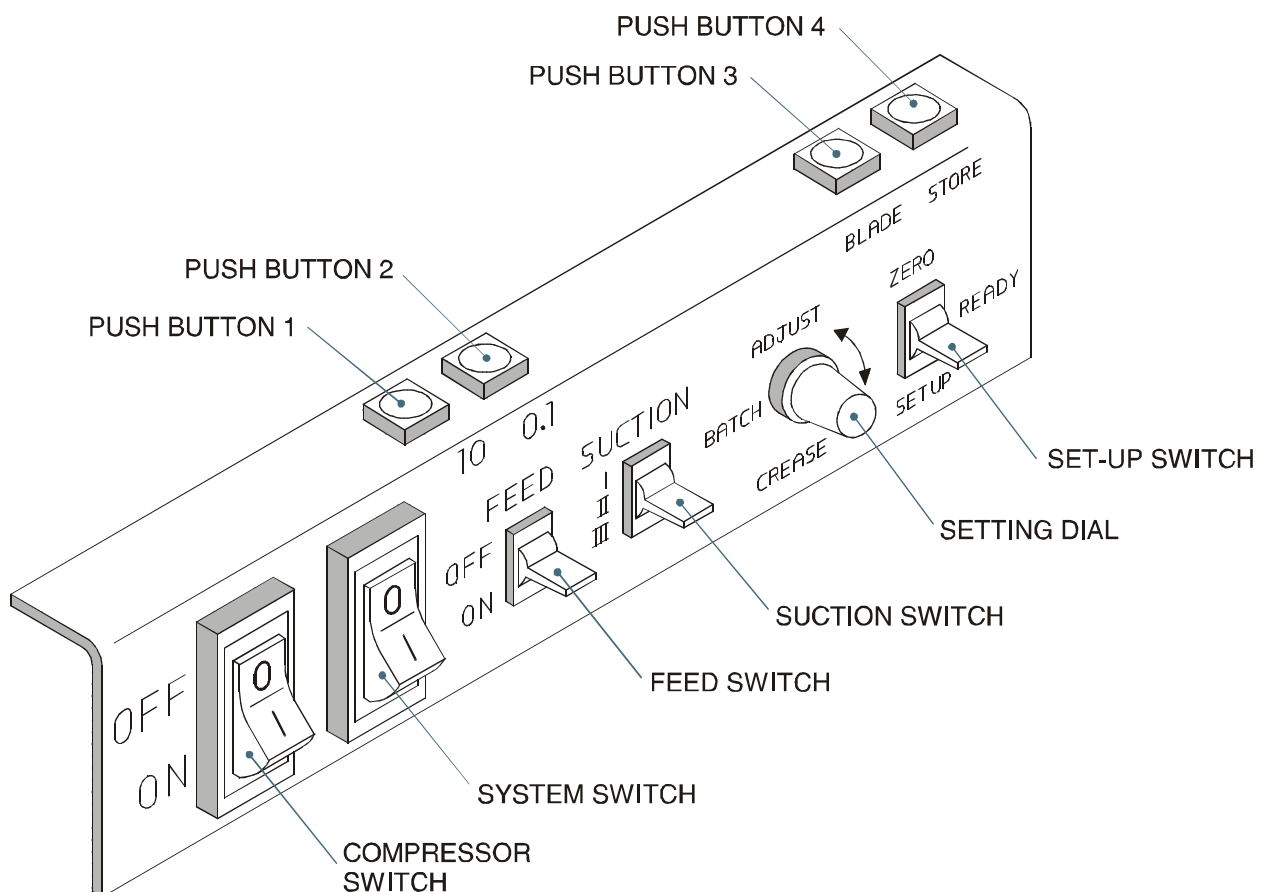

Features on the Control Panel

Push Button 1

Used for adjusting a crease position in increments of 10mm when used with the setting dial (in the **Crease** mode of operation).

Used for adjusting the number of sheets in a booklet, in multiples of 10, when used with the setting dial (in the **Booklet Maker** mode of operation).

Push Button 2

Used for adjusting a crease position in increments of 0.1mm when used with the setting dial (in the **Crease** mode of operation).

Used for adjusting the number of sheets in a booklet, in multiples of 1, when used with the setting dial (in the **Booklet Maker** mode of operation).

Push Button 3

Used for locating the bottom blade or anvil to its 'Top Dead Centre' position in order to set the blade pressure (whilst the system switch is on).

Also used to return the blade to the 'Home' position after a 'Crunch' if required.

Push Button 4

Allows the operator to save a created program. When also used with the setting dial the operator can scroll through the stored addresses.

Set-up switch

Allows the operator to enter and subsequently edit or read a stored program. Also resets the batch quantity.

Setting dial

Allows the operator to scroll through stored addresses and programs, increase or decrease the batch quantity and set a crease position.

Suction switch

Allows the operator to vary the length of suction on the sheet of paper being fed.

Position I – For very short sheets.

Position II – For short non-standard sheets.

Position III – For all standard size sheets, general purpose, and Stream Feed.

Feed switch

Allows the operator to start and stop feeding sheets.

System switch

When activated the system switch will operate the motors in order to begin the creasing sequence.

Compressor switch

Allows the operator to switch off the compressor unit in order to utilise the machine to manually feed sheets.

Adjusting the Paper Guides

Insert a sample sheet into the infeed tray of the Booklet Maker. Adjust the width of the paper guides, by squeezing them together, until the sample sheet slides freely in the guides.

Adjusting the Sliding Back Stop

With the sample sheet in its downward resting position, adjust the sliding back stop until it is approximately 5mm to 10mm clear of the back edge of the sample sheet.

Aligning the Booklet Maker and Creaser Unit

The handwheel on the front of the Creasing Unit can now be used to align the Booklet Maker and the Creasing Unit. The correct alignment is achieved when the alignment arrow on the Creasing Unit is lined up with the rear paper guide of the Booklet Maker.

Rear Paper Guide

Alignment Arrow

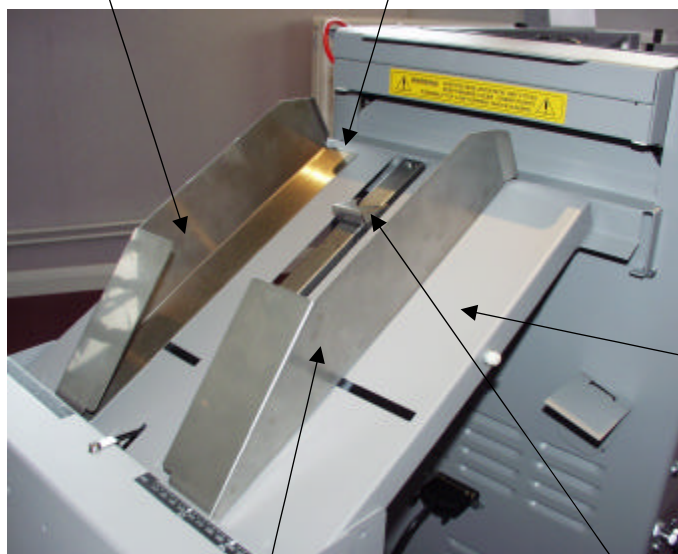

Infeed Tray

Front Paper Guide

Sliding Back Stop

Programming the machine for Booklet Maker operation

1. Switch the power 'on' by turning the Emergency stop button clockwise to release the safety latch. The display is now switched on. Allow the booklet maker to run through its program, it will confirm a ready signal with two blips and a constant flashing of its light. If the light does not constantly flash and the optional Square Back System is fitted, make sure that the Square Back System mains switch is switched on.
2. If the text on the display contains the words '**Books or Booklet**', push the Set-up switch down and set the Booklet up as described from step 3 onwards.
If the text on the display contains the word '**Creases**' the machine is in the Crease mode of operation.
To change the mode of operation to Booklet Maker proceed as follows:-
 - (i) Push the Set-up switch down.
 - (ii) Hold Pushbutton 1 down and turn the setting dial clockwise one 'click', the display now reads '10 Sheet Booklet'.

Setting the number of sheets in the Booklet

3. Hold down Pushbutton 1 and turn the Setting Dial to change the number of sheets in multiples of 10, or hold down Pushbutton 2 and turn the Setting Dial to change the number of sheets in multiples of 1.
Release the Pushbutton.

Setting the Creasing Style.

4. Turn the setting dial clockwise one more 'click'. **Display reads 'Creasing Style'**
Hold down Pushbutton 1 and turn the Setting Dial clockwise or anti-clockwise to set the Creasing Style to 'Cover Only', 'Cover & Centre', 'All Sheets' or 'None' as required.

Release the Pushbutton.

Setting the Crease Position.

5. Turn the setting dial clockwise one more 'click'. **Display reads 'Book Centre' (From Lead Edge).**
Hold down Pushbutton 1 and turn the Setting Dial to change the 'Book Centre' in multiples of 10mm, or hold down Pushbutton 2 and turn the Setting Dial to change the 'Book Centre' in multiples of 0.1mm.

Release the Pushbutton.

Setting the Cover Creases.

1 Crease (in Centre), or 3 Creases (Centre with Hinges).

6. Turn the setting dial clockwise one more 'click'. **Display reads 'Cover Creases'**
Hold down Pushbutton 1 and turn the Setting Dial to select '**Cover Creases 1 (Single in Centre)**' or '**Cover Creases 3 (Centre with Hinges)**'. See FIG. 1.

Release the Pushbutton.

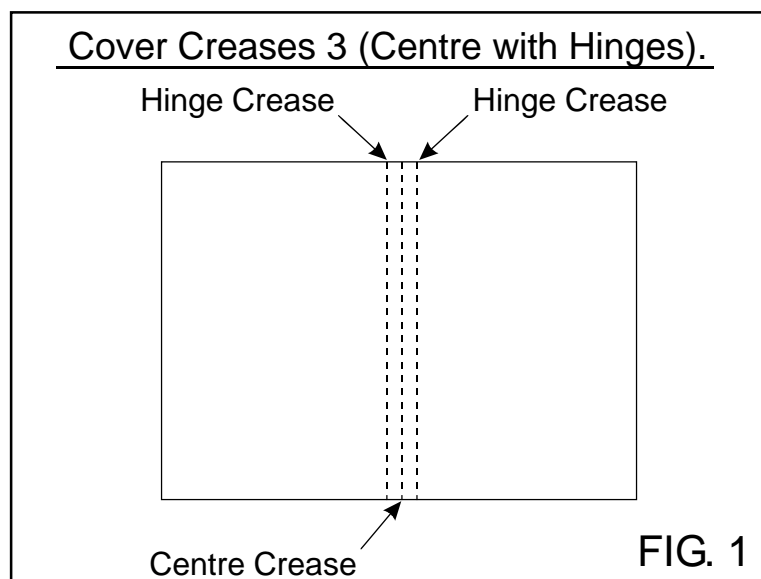

Setting the Hinge Positions.

7. If 3 cover creases (Centre with Hinges) have been selected, set the hinge positions as follows.

Turn the setting dial clockwise one more 'click'. **Display reads 'Hinge Positions'**

Hold down Pushbutton 1 and turn the Setting Dial clockwise or anti-clockwise to select **Hinge Position 4.0** (Minimum) or **Hinge Position 10.0** (Maximum).

Release Pushbutton 1.

Hold down Pushbutton 2 and turn the Setting Dial clockwise or anti-clockwise to set the value of the hinge position.

Release Pushbutton 2.

Setting the Batch Quantity.

8. This function is not available in Booklet Mode

Setting Pulse Feed or Stream Feed.

9. (i) Push the Set-up switch down.
(ii) Turn the setting dial anti-clockwise until the **Display reads 'PULSE FEED SELECTED'** or **'STREAM FEED SELECTED'**
(iii) Press Pushbutton 1 to toggle between Pulse Feed and Stream Feed.

NOTE.

Stream feed will only work when the Suction Switch is in position III.

Storing the Program.

10. The booklet maker settings can now be stored as follows:-
(i) Flick the Set-up switch to Ready.
(ii) Turn the Setting Dial in either direction to cycle through the 9 memory addresses available. To store the booklet to the displayed address press Push Button 4.

Running the machine

11. To run the job with the selected settings, activate both the System switch and the Compressor switch. Flick the Feed switch to 'On' and the sheets will begin to feed. To stop feeding the media at anytime during the program, flick the Feed switch to 'Off'.

Reading stored Programs

With the power switched on, hold down Push Button 4 and turn the Setting Dial in either direction to cycle through the memory addresses.

Clearing Booklet sheets from the Booklet Maker Infeed Tray.

If for any reason the Feed switch is turned off, during booklet making operation, booklet sheets may remain in the Booklet Maker infeed tray.

To clear the sheets through into the Booklet Maker, (to be folded and stapled), press Pushbutton 2.

Using the Booklet Maker in Manual Mode.

1. The Feed Switch must be in the 'OFF' position.
2. Press pushbutton 2.
3. Feed the booklet sheets, by hand, into the infeed tray of the Booklet Maker.
The booklet sheets will automatically feed into the Booklet Maker and be folded and stapled.

Single Sheet Booklet.

IMPORTANT.

1. If producing a single sheet booklet without stitch it will be necessary to set the Creasing Style to 'All Sheets' or 'Cover & Centre' **not** 'Cover Only' or 'None'.
2. If the 'Square Back System' is installed with the Booklet Maker ensure that the switch on the 'Square Back System' is set in the position shown below.

Set Switch in
this Position



Programming the machine for Creaser operation

1. Switch the power 'on' by turning the Emergency stop button clockwise to release the safety latch. The display is now switched on.
2. If the text on the display contains the words '**Creases**', push the Set-up switch down and set the crease positions as described from step 3 onwards.

If the text on the display contains the words '**Books or Booklet**' the machine is in the Booklet Maker mode of operation.

To change the mode of operation to Creaser proceed as follows:-

- (i) Push the Set-up switch down.
- (ii) Hold Pushbutton 1 down and turn the setting dial anti-clockwise until the display reads '**Crease Only Mode**'. Set the crease positions as described from step 3 onwards.

Setting the crease positions

3. Turn the Setting Dial clockwise one 'click'. **Display reads 'First Crease'**
4. Hold down Button 1 and turn the Setting Dial to increment the first crease position by 10mm per 'click'. To increment by 0.1mm hold down Button 2 and turn the Setting Dial. Release the buttons to set the crease position.
First Crease position will be displayed ie. 'First Crease 98.7'
5. With the push buttons released, turn the Setting Dial clockwise one 'click' to set the second crease.
Display reads 'Second Crease'
6. Repeat step 4. to allow for the second crease to be set. A maximum of 9 creases can be set into a program. To edit any of the creases entered into the program, turn the Setting dial in either direction to locate the crease. Once the crease is displayed repeat step 4.

Storing the crease positions

7. Once the crease positions are correctly entered, flick the Set-up switch to 'Ready'.
Display reads 'To Save Settings in Program ? Push STORE'
8. Turn the Setting dial in either direction to cycle through the 9 memory addresses available. To store the settings to the displayed address, press Button 4.

Important

If storage for the above crease positions is not required, operate the Feed switch and the machine will run. If the settings were not stored when given the opportunity, flick the Set-up switch to 'Set-up' and then back to 'Ready' and repeat step 8. However, if the Emergency stop button is pressed before storing the settings, they will be lost.

Setting the Batch Quantity.

9. Turn the setting dial in either direction. **Display reads 'Batch at ?? Sheets'**. Turn the setting dial clockwise to increase the batch quantity in multiples of 10, or anti-clockwise to decrease the batch quantity in multiples of 10.

Setting Pulse Feed or Stream Feed.

10. (i) Push the Set-up switch down.
(ii) Turn the setting dial anti-clockwise until the **Display reads 'PULSE FEED SELECTED'** or **'STREAM FEED SELECTED'**
(iii) Press Pushbutton 1 to toggle between Pulse Feed and Stream Feed.

NOTE.

Stream feed will only work when the Suction Switch is in position III.

- (iv) Flick Set-up switch to 'Ready' and then store the settings in the required memory address as described in step 8.

Running the machine

11. To run the job with the selected settings, activate both the System switch and the Compressor switch. Flick the Feed switch to 'On' and the sheets will begin to feed. To stop feeding the media at anytime during the program, flick the Feed switch to 'off'. The machine will complete its creasing operation if a sheet has already been fed through the paper gate.

Reading stored Programs

With the power switched on, hold down Push Button 4 and turn the Setting Dial in either direction to cycle through the memory addresses. When any of the 9 addresses are displayed, flick the Set-up switch to 'Set-up'.

To view or edit any of the creases within the program see step 3.

Clearing a stored Program within the memory address

Whilst viewing any of the stored programs, turn the Setting Dial one 'click' past the last available creasing position.

Display reads 'Press STORE button to clear all creases'

Press Push Button 4 to clear the stored settings.

Paper jamming

In the event of a paper jam occurring whilst the machine is operating the display will read '**crunch**'. In order to remove the paper causing the jam, Push Button 1 and Push Button 2 can be used to manually operate the motor.

Push Button 1 – will drive paper forward, in short pulses.

Push Button 2 – will drive paper in reverse, in short pulses.

When pressed, the push button will activate the rollers for a short movement. For continuous movement, press and release the push button repeatedly.

If the sheet remains jammed, check that the lower blade / anvil is not clamping the sheet. If so, press Push Button 3 to lower the blade / anvil to release the jammed sheet.

Setting the machine to operate in manual mode

In order to feed heavy stock, very small or very large sheets, embossed or even irregular shaped sheets, it may be required to operate the machine manually.

The machine can be programmed and set up in exactly the same way as explained when operating the machine automatically. However, when setting up the machine the paper gate must be raised to its highest position for the sheets to be fed freely. Operating the machine manually will also require the suction length to be continuous in order to accommodate various types of stock. Therefore, the suction length switch must be positioned at 'III'.

The machine can now be started by activating the System switch to 'on'. **Do not activate the Compressor switch.** Flick the Feed switch to 'on' and begin to slide the sheets individually through the paper gate until they are driven by the drive belts. To stop feeding the sheets, flick the Feed switch to 'off' and then the System switch to 'off'.

Setting the machine to operate In automatic mode

1. Set the gap between the paper gate and the vacuum roller to approximately twice the thickness of the stock to be creased.
2. Place the stock to be creased onto the loading table against the fixed side lay.
3. Release the clamps on the adjustable side lay and slide up to the paper stack allowing a gap of approximately 0.5mm (1/64 inch) between the paper and the side lay.
4. Place the backstop on to the adjustable side lay and slide up to the paper stack, also allowing a gap (as stated in the above step) before clamping.
5. Turn the Emergency Stop button clockwise to switch the power on.
6. Flick the Set-Up switch to 'set-up'.
7. Hold down either Push Button 1 (10mm) or Push Button 2 (0.1mm) and turn the setting dial to program a crease position.
8. Release the buttons and turn the setting dial to program a new crease position.
9. Once all of the desired crease positions have been programmed, flick the Set-Up switch to 'ready'.
10. Press both the Compressor switch and the System switch to 'on'.
11. To begin feeding sheets, flick the Feed switch on.

In order to manually feed sheets see instructions on page 16.

Setting the Machine

Adjusting the Paper Gate

The standard setting for horizontal adjustment of the paper gate is 6.5mm (1/4") away from the mounting block. Turn disc J to make this adjustment. This setting is only intended as a guide, for instance, sheets with an upward curl will require this setting to be increased. Set the height of the Paper Gate to approximately two thicknesses of paper, by turning knob K. An excessive gap is a most likely cause of double sheet feeding.

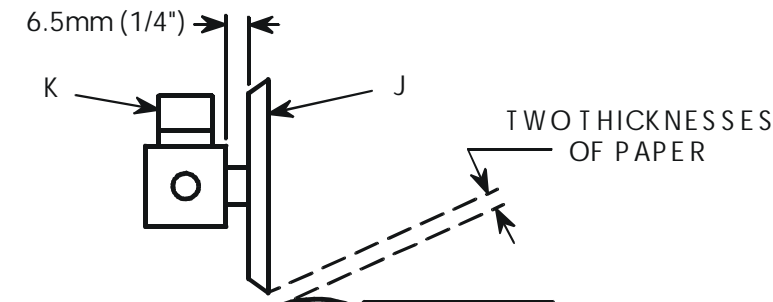

During Booklet Making if the stock varies in thickness it may feed better with the 6.5mm setting being set to zero, and the Paper Gate setting should be reduced to a single sheet of the thickest stock.

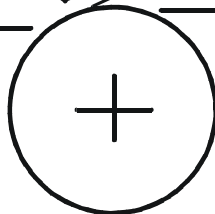

IMPORTANT:-

To avoid possible damage to the suction drum, when adjusting the paper gate height, ensure that the disc is located over a solid section of the suction drum and not over a slot in the drum.

Do not adjust the paper gate while the machine is running.

Setting the suction slot

The suction slot is located inside the vacuum roller and can be adjusted by releasing and moving the suction slot knob horizontally in either direction to the required position.

For light stocks set the knob to the left and for heavier stocks set the knob to the right.

FIG 8.1

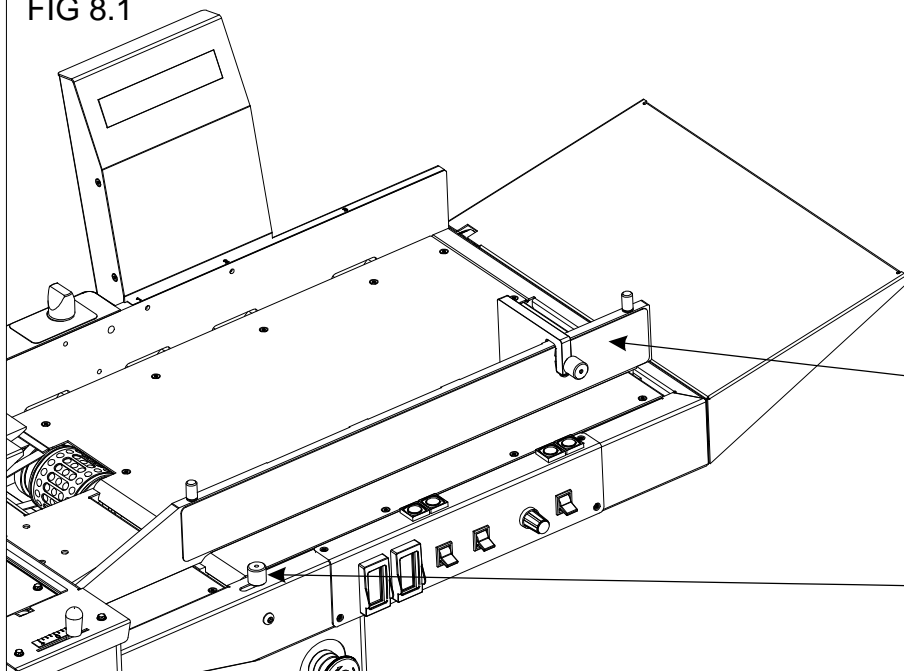

During Booklet making if the stock varies in thickness it may feed better with the suction knob set fully to the left.

Adjustable Side Lay

Suction Slot Knob

Setting the Adjustable Side Lay

Place the paper stack on to the loading table and slide up to the fixed side lay and paper gate. Release the clamps located at each end of the side lay and slide up towards the paper stack as demonstrated in fig 8.1. Allow a gap of approximately 0.5mm (1/64 inch) between the paper and the side lay.

Setting the Back-Stop

Place the back-stop on to the adjustable side lay and slide up towards the paper stack allowing a gap (as specified in the above step) before clamping. When the extension table is used for feeding longer sheets, remove clamp type back stop and use the magnetic type back stop as shown in fig. 10.2.

Setting the Air Distribution

Depending on the length of the sheet to be creased, the air distribution knob can be rotated to various positions in order to supply air to different ports. Position 1 is recommended for most sheet sizes. However, a better result may be obtained by using the below settings or by experimentation.

- Position**
- 1 – For A5 sheets or 8 inches long, front port and port 1 open.
 - 2 – For A4 sheets or 11 inches long, front port and port 2 open.
 - 3 – For A3 sheets or 17 inches long, front port and port 3 open.
 - 0 – For longer sheets in order to supply air to the centre of the stack, port 1 and port 2 open.

Setting the Air Separation Pressure

To control the amount of air supplied to the ports, the air separation knob can be adjusted by first rotating the knob to unlock its position, then push the knob down to the required position and rotate the knob to re-lock its position.

Setting the Roller Tilt Mechanism

The roller tilt mechanism has been designed to compensate for when the creasing position on the sheet is not square. This could be due to an inaccuracy in the media or if the roller tilt mechanism has been incorrectly set. The mechanism will be set to zero (square) when the machine is supplied.

To set the mechanism, unlock the roller tilt knob located below the roller tilting handle by turning anti-clockwise. Move the roller tilt handle left or right in order to compensate for any inaccuracy. When the position is set, ensure to lock the roller tilt knob before operating the machine. Repeat the above procedure until the creasing position is square.

Setting the positions of drive wheels and hubs

It is important that the drive wheels and drive hubs on the roller shafts are arranged evenly across the width of the media being creased. This is done to ensure that the media is accurately driven and supported through the rollers.

The drive wheels and hubs are fixed to the rollers by means of a grub screw. To locate this grub screw the rollers can be rotated by operating the motor manually.

DO NOT ROTATE THE DRIVE ROLLERS BY HAND.

To operate the motors manually, switch the machine 'on' at the Emergency Stop switch. Whilst holding down Push Button 1, flick the Set-up switch to 'set up'. The display will now read '**hAndLE**'. Press the System switch to 'on' and use Push Button 1 (forward) and Push Button 2 (reverse) to manually rotate the rollers in short pulses. Rotate the rollers until the grub screw is located. Lift the exit guard and the machine will switch 'off' automatically. Loosen the drive wheels and hubs by using a 2mm allen key. Arrange the drive wheels and hubs as shown in fig 10.1. In order to avoid to marking on some types of media ensure a gap between the drive wheels and drive hubs. This procedure should be repeated when installing perforating blades and anvils onto the drive wheels and hubs.

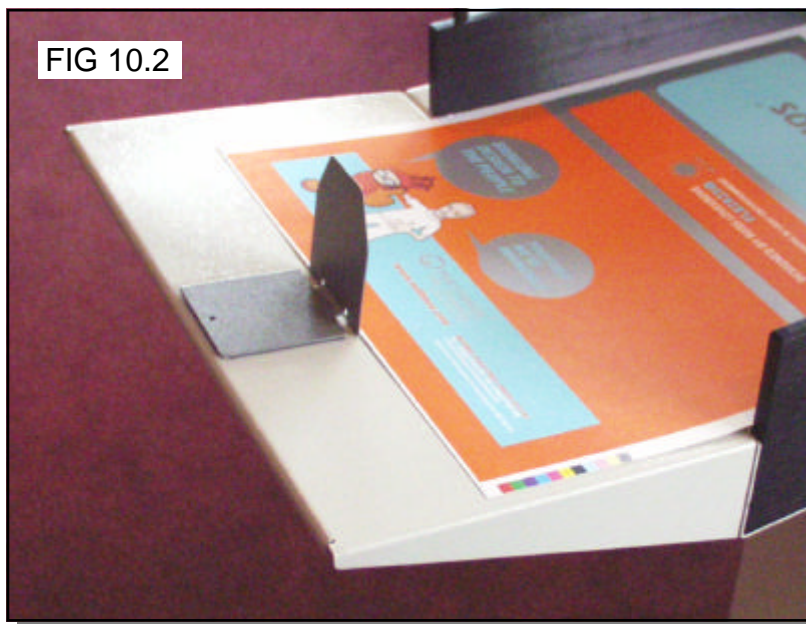
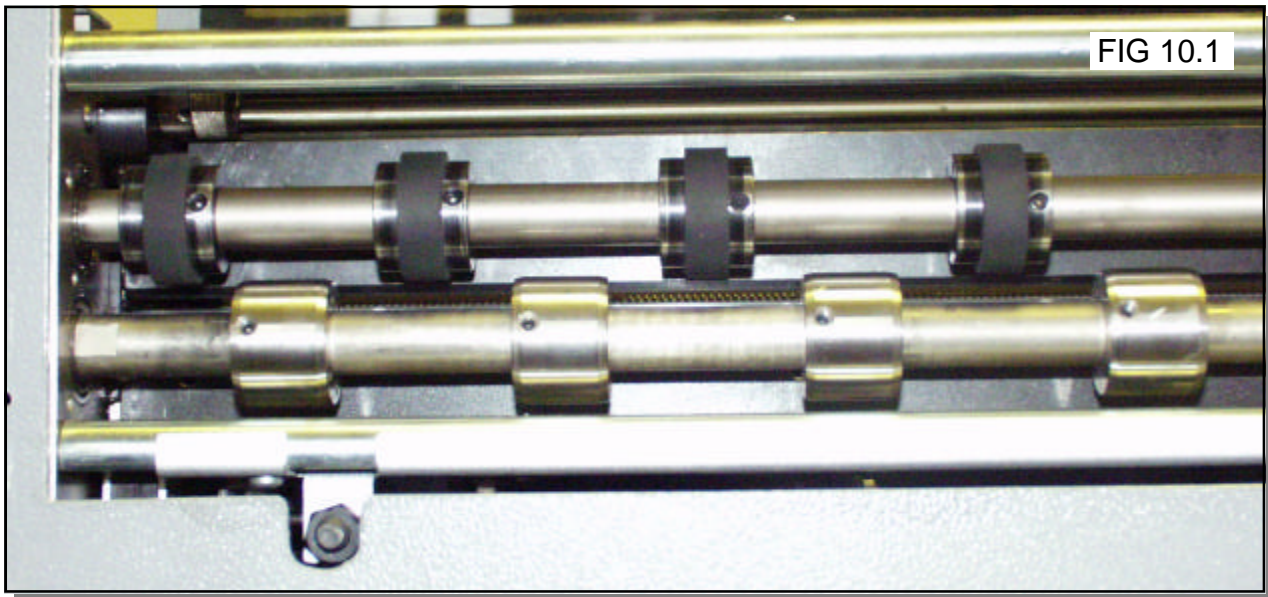

Setting the extension table

The extension table can be fixed to the machine in order to feed through longer sheets. The table can be supported by the two fixing screws as shown on page 5. The back stop used on the stacker assembly can also be used to support the paper stack on the extension as shown in fig 10.2.

Setting the Measurement System (Imperial or Metric)

To set the measurement system for Imperial (Inch) or Metric (mm) the following procedure is necessary.

- Power set to On
- Suction and Feed switches in their Up Position (Off)
- Press and Hold Down the Store Push Button (PB 4) and operate the Feed Switch Down (On) the display now shows either Inch or Metric.
- Release the Store Push Button and using the Selector Knob turn right for Imperial or Left for Metric.
- Leave the Display showing the required type of measurement system, operate the Feed Switch Up (Off)

The stacker unit on the Creaser is used to catch the sheets once they have been creased or perforated.

NOTE:-This stacker unit is not fitted when the machine is being used as a Booklet maker.

Setting the Stacker assembly

1. Assemble the stacker unit to the machine as shown in fig 13.1 below.

Important

Ensure that the stacker unit has been assembled to the machine properly. However, if it has not, the connection on the magnetic switch will be broken and the machine will not operate (see Trouble shooting pages for details).

There are two adjustable side guides on the stacker unit (a left hand and a right hand). The adjustable right hand guide is used to control the way in which the paper is collated by setting its position on the stacker bed. It is secured to the bed by means of a magnetic strip.

2. Place a single sheet (from the stack to be creased / perforated) onto the stacker bed so that the right hand guide can be adjusted into position. Position the right hand guide to leave a minimum clearance of approximately 1mm each side of the sheet.

FIG 13.1

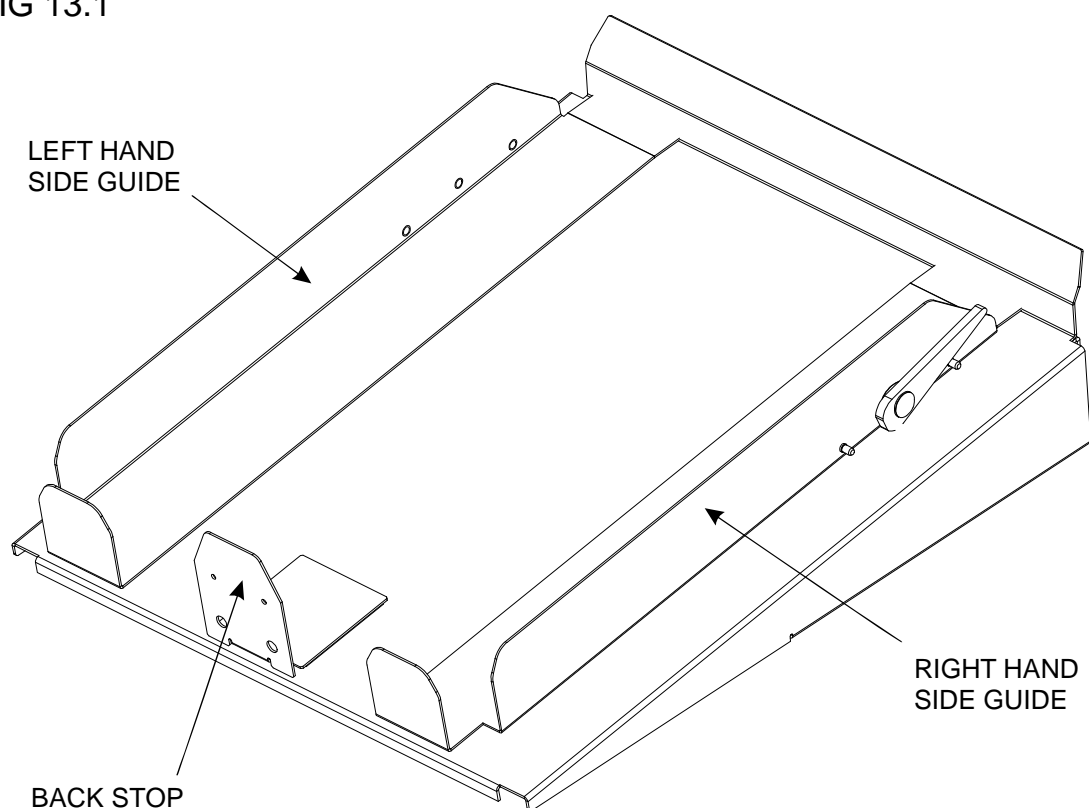

3. Whilst the sheet is between the two guides on the stacker bed, set the distance between the top of the sheet and the edge at which the stacker is attached to the machine to approximately 5mm.
4. For shorter sheets, the back stop can be used (as demonstrated in fig. 10.2) to adjust the position of the paper stack.



TIPS

- One of the back stops supplied with the machine (on the stacker assembly) can also be used as a tool holder as demonstrated in the photograph (left).
- The back stop can also be used on the extension table in order to retain the position of longer sheets (see fig 10.2)

Once the machine is set-up, the Creaser can be used to perforate or crease.

Note

Perforating and creasing can be carried out simultaneously. However, if any adjustment is made to the roller tilt mechanism in order to compensate for the perforation line being 'out of square', this may effect the accuracy of the crease. If this occurs creasing and perforating must be carried out as separate operations.

The components and tools required to install the perforator are contained in the despatch kit supplied with the machine, they are listed below.

- 1 off Set of standard perforation '56 tooth' blades.
- 1 off Set of standard hardened anvils.
- 1 off Perforator stripper.
- 1 off Scoring wheel
- 1 off 3mm bondhus wrench / allen key
- 1 off 2mm bondhus wrench / allen key

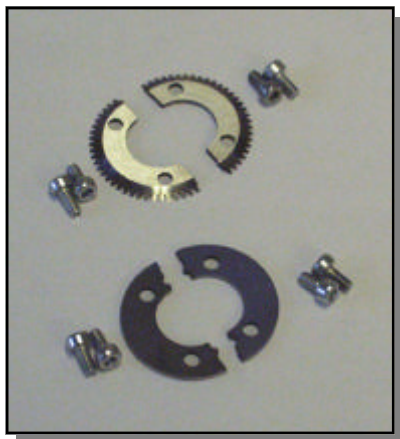

The perforator blades are split into two matching halves and are fitted to the drive wheels as shown in the Photograph using the four screws supplied.

A hardened anvil is fitted to the drive hub as shown in the photograph also using the four screws supplied. Again the anvils are made from matching halves.

Important: The perforator blades are very sharp and care must be taken whilst handling. Do not mix the matching pairs of blades or anvils.

Perforating 'Spares' kits

For perforating and other types of paper, various spares kits are available which can be assembled to the machine in the same fashion. They are listed below along with a range of scoring wheels,

Perforating blades	56 teeth	Part Number 1-99-41	–	Standard stock / fine perforations.
	28 teeth	Part Number 1-99-12	–	Medium stock / medium perforations.
	20 teeth	Part Number 1-99-10	–	Heavy stock / coarse perforations.
Anvils	Standard	Part Number 1-99-35	–	For all blade types

All of the blades and anvils are supplied with fixings.

***Perforator stripper** Standard Part Number **78-013**

*It is recommended that for multiple perforations, a separate perforator stripper is used for every perforating blade set fitted in the creasing unit.

Setting the machine

1. Turn the mains supply to the machine 'off'.
2. Remove the stacker unit and open the exit guard.
3. Locate and remove the blades / anvils from the despatch kit supplied with the machine.
4. Using the 2mm allen key (supplied), loosen the drive wheel that is to accommodate the blades.
5. Slide the drive wheel away from any obstructing drive wheels or hubs in order to mount the blades.

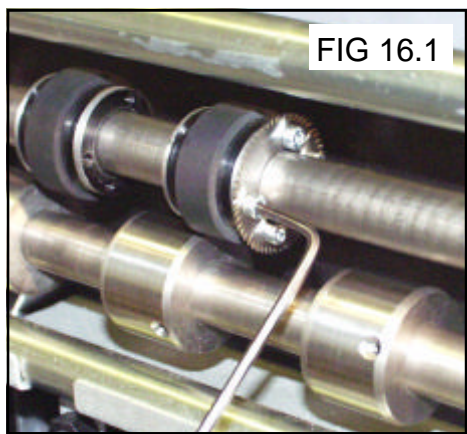

6. Using the 2.5mm allen key (supplied), take one of the matching pairs and mount on to the drive wheel. Do not secure the blade.
7. Mount the other matching pair to the drive wheel as shown (fig 16.1). Secure the blades to the wheel ensuring not to over tighten grub screw.
8. Mark on a single sheet the desired perforating position. Feed the sheet through the machine manually until the mark can be seen. Use this mark to assist in fixing the position of the perforating drive wheel to the roller drive shaft.

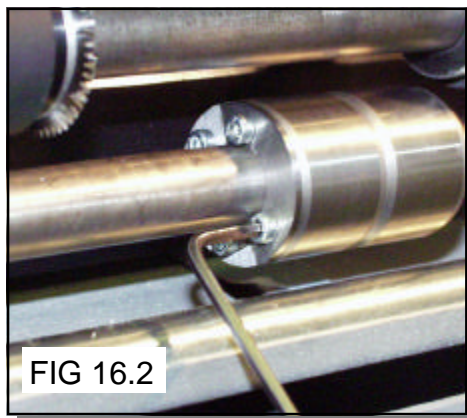

9. Using the 2mm allen key, loosen the drive hub nearest the perforating drive. Slide the drive hub away from any obstructing drive wheels or hubs in order to mount the anvils.
10. Using the 2,5mm allen key, take one of the matching pairs of anvils and mount to the drive hub. Do not secure the anvil.

11. Mount the other anvil ensuring that they have matched on the drive hub. Secure the anvil to the hub ensuring not to over tighten grub screw as shown in fig 16.2.
12. Slide the drive hub towards the perforating drive wheel until there is a clearance of 0.5mm.
13. To prevent damage to the blades or the anvils, do not force the drive wheel against the hub.
14. Fix the perforator stripper adjacent to the drive wheel to the as shown.
15. Operate the machine and test the perforations for form.

It is important that the drive hubs are arranged evenly across the width of the paper in order to reduce the risk of jamming.

For multiple perforations repeat the above procedure.

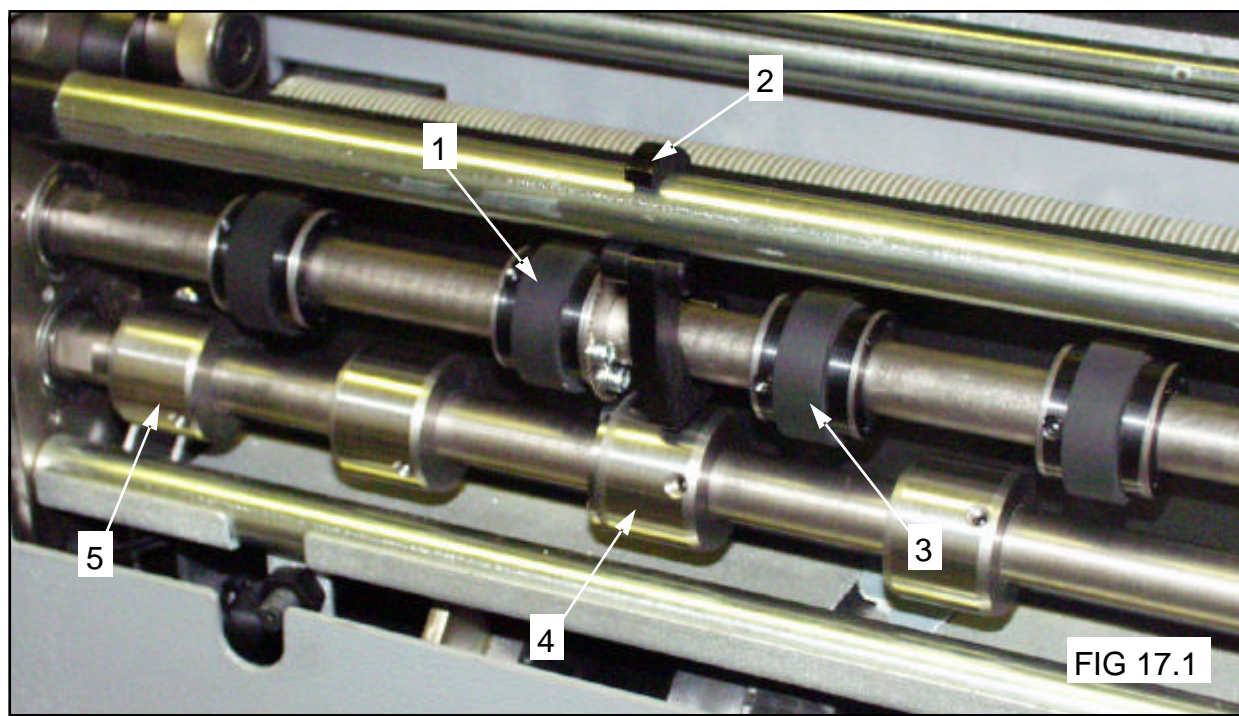

Fig 17.1 demonstrates a typical set-up for perforating sheets.

- | | |
|---|-----------------------------------|
| 1 – Perforating drive wheel with mounted blades | 4 – Drive hub with mounted anvils |
| 2 – Perforator stripper | 5 – Standard drive hub |
| 3 – Standard drive wheel | |

Always remove blades and anvils once the perforating operation has been completed to avoid marking on digital or delicate media.

Adjusting the blade pressure (no paper required)

1. Turn the Emergency Stop button clockwise to switch the machine 'on'.
2. Activate the system switch and the motors will begin to operate.
3. Flick the 'Feed' switch to 'on' and then back to 'off' to ensure that the lower blade / anvil is at its bottom position.
4. Press Push Button 3, the machine will automatically switch off and the lower blade / anvil is set its top position where the pressure can be adjusted. Raise the exit guard.
5. Using a 6mm allen key, unlock the shoulder bolts (labelled with scale transfer) positioned at each end of the creasing blade.
6. Turn the adjustment cam to adjust the blade pressure. Increasing the gradient on the scale will increase the blade pressure.
7. Ensure that the shoulder bolts are locked after setting.

The diagram below demonstrates the adjustment of blade pressure

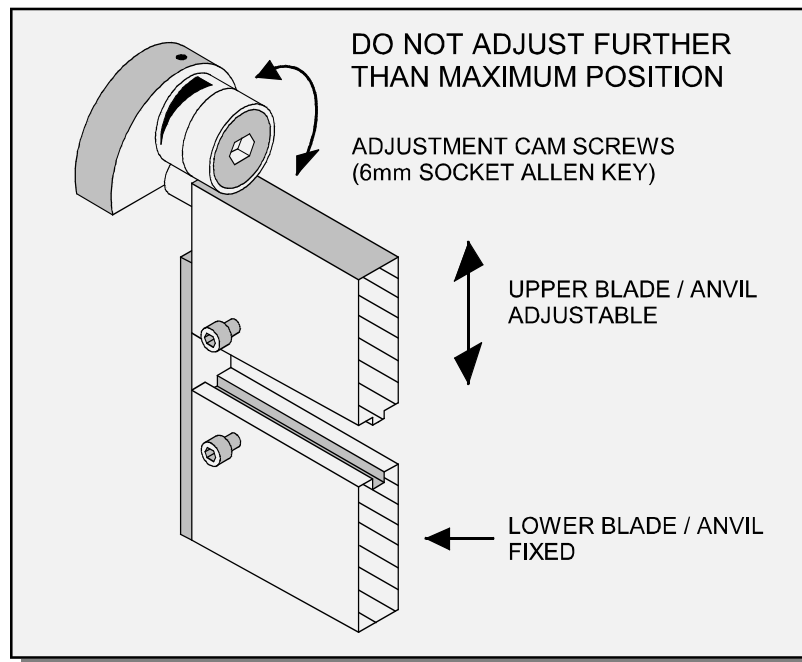

Adjusting the blade alignment

It is extremely important that the blade and anvil assembly within the creasing unit is correctly aligned. Misalignment of the blade or anvil can lead to damaged profiles and subsequently poor quality creasing so it must, therefore, be corrected immediately.

If the blade set is misaligned, the media being driven will be subject to scoring or even tearing at any point along the crease line. **Please note that to avoid damage to the blade set, adjustment should only be made in small increments.** The sketch below demonstrates how the blade alignment can be carried out. Adjustment can be made at either of the blade or anvil. The two clearance holes positioned above the roller tilt mechanism are the front alignment (one for blade, one for anvil). The two holes are repeated on the back of the machine for the back alignment.

1. Remove the stacker unit from the Creaser
2. Unlock and centralise the roller tilt mechanism in order to locate the heads of the front alignment screws.
3. Using a 3mm allen key, loosen the cap head type locking screws located on the front face at both ends of the blade /anvil as shown below.
4. Using a 4mm allen key, locate the two front or back alignment screws in the side frame in order to adjust the blade / anvil.
5. The upper screw of the two, will adjust the upper blade / anvil whereas the lower screw will adjust the lower blade / anvil both in very small increments.
6. In order to obtain the required position, adjust either the blade or the anvil by a small amount and then operate the machine to test the form of the crease. Repeat the exercise until centralisation is located.
7. Using a 3mm allen key, lock the cap head type screws (as per step 3) on both the upper and lower blade / anvil.

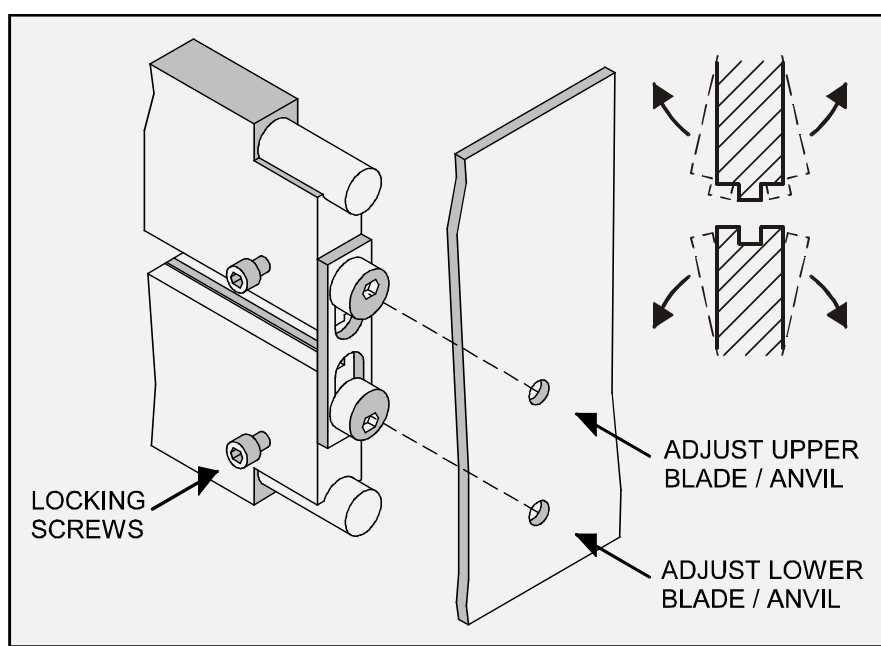

1. Before removing the blade assembly, ensure that the lower blade / anvil is NOT at 'top dead centre', ie. Push Button 3 has not been pressed. Switch the machine off.
2. Remove the stacker unit and lift the exit guard.

Blade Extractor Tools

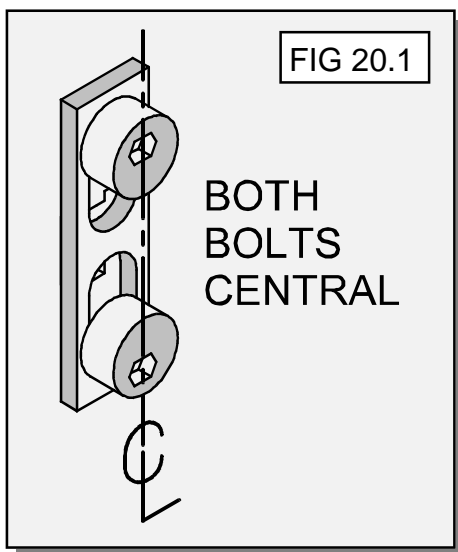
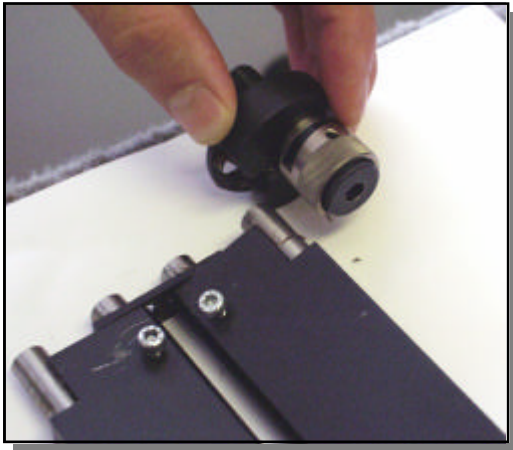
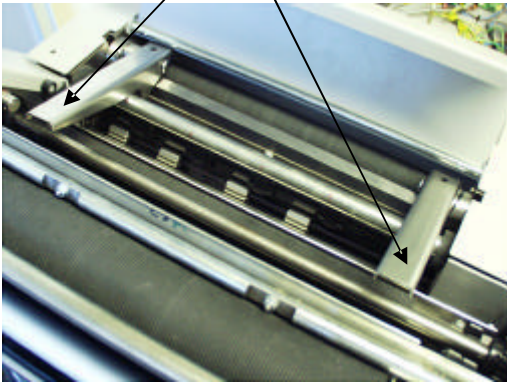

3. Using a 6mm allen key, loosen the socket head screws located inside the blade adjustment cams. Remove the screws and the blade adjustment cams.
4. Insert the blade extractor tools (70-055-01 & 70-055-02) into the holes in the adjustment links, as shown. Push downwards on the handles of the blade extractor tools to release the blade assembly from the power links.
5. Slide the blade assembly out of the creasing unit and lay it on a flat surface.
6. Slide the adjustment links away from the dowels located in the ends of the blades / anvils as shown in the photograph (left)
7. Place the new blade set into position. Check that the eccentric shoulder bolts on the link plates have been positioned as shown in fig 20.1.
8. (Upper blade / anvil only)
Slide the adjustment links onto the dowels.
9. Slide the new blade set into the slots of the creasing unit as shown in fig. 21.1.

Locate the blade extractor tools into the holes in the adjustment links as shown. Pull the handles of the blade extractor tools upwards to engage the blade assembly back into the power links.
10. Set the cam graphics for both ends of the blade / anvil to their lowest point on the scale (ie. When the mark on the scale reaches the mark on cam holder) Fasten the socket head screws on the adjustment cams until they are tight.

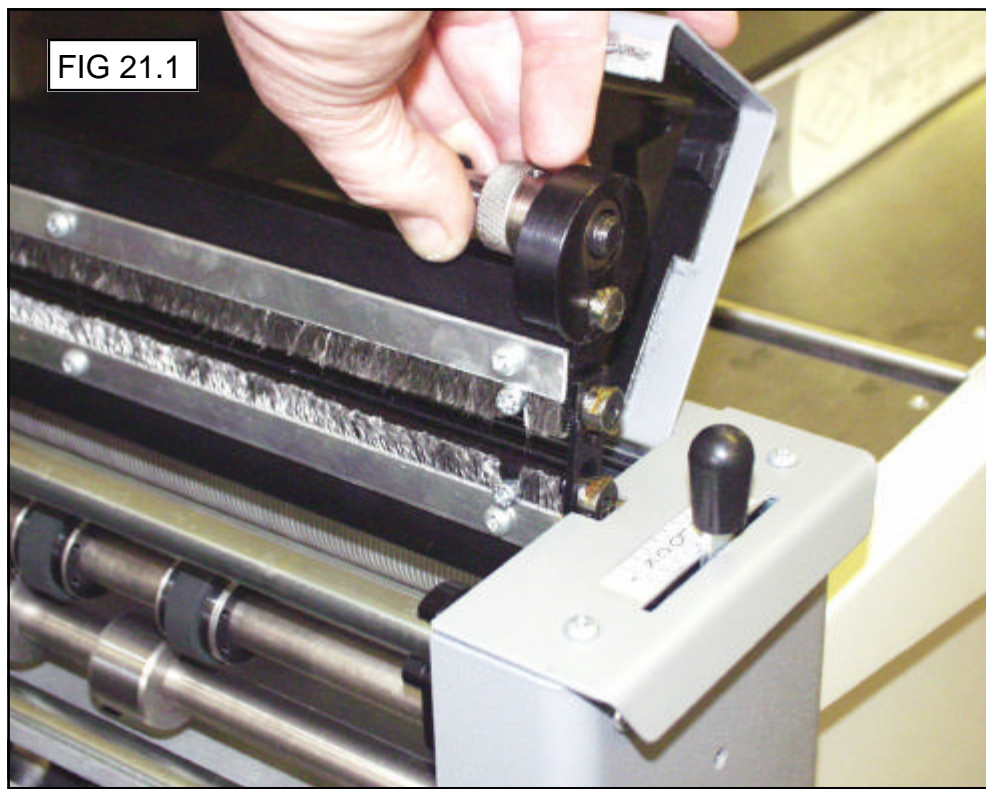

11. Push the exit guard down and replace the stacker assembly before operating the machine.
12. Switch the machine on and test the crease for form.

If the pressure and the alignment of the crease is not to a satisfactory level, see pages 27 – 29 to adjust the creasing line.

'Spares' kits

In the event of any damaged or lost components within the blade assembly, spares kits are available on request. However, components within the blade set can not be ordered separately ie single blade or anvil.

For lighter stock, a 'narrow' blade set is also available.

Standard (Wide) Blade set

Part number 76-213-01

Consisting of a standard blade and anvil, blade brushes, blade links and alignment bolts.

Narrow Blade set

Part number 76-213-02

Consisting of a special narrow anvil, a standard blade, blade brushes, blade links and alignment bolts.

Warning: Damage may occur to the operating mechanism and will invalidate the manufacturers warranty if the narrow blade set is used with material in excess of 150gsm.

Paper crease out of square

- Check that the sheets are all square and exactly the same size before loading the stack on to the table.
- Check that the roller tilt mechanism is correctly set and locked in position.
- Check that the adjustable side lay has been correctly positioned ie. No further than 0.5mm from the paper stack.

Paper jamming

- Check that the leading edge of the paper is not being damaged by the paper gate. If this is occurring, check that the suction slot and the paper gate have been correctly set.
- Check that the first crease position is not too close to the leading edge of the paper. a minimum distance of 32mm is recommended.

Machine will not start

- Check the power supply to the machine.
- Check that the emergency stop button has been released.
- Check that the exit guard is down.
- Check that the stacker unit is located correctly and has not been disconnected from the magnetic switch.
- Check that the lower blade / anvil is connecting to the home switch (mounted below the lower blade / anvil).
- If the optional **Square Back System** is fitted, make sure that it is switched on.

Paper not feeding

- Check that the paper stack is not too high or too heavy for the feeder. The height of the paper stack should be defined by the weight and the size of the stock being creased.
- Ensure that the adjustable side lay is not pressed against the paper stack. However, if the clearance between the adjustable side lay and the paper stack is too great, the air supply will escape instead of blowing through the paper thus making it difficult to feed.

- Check that the clearance between the paper gate and the suction roller is not set too low.
- On digital media, the feeding performance may be improved if the leading edge of the stack is trimmed before loading onto the Creaser.
- Check that the air distribution has been correctly set.
- Check that the air separation has been set high enough to feed the sheets.
- For heavy stocks, very small or very large sheets, embossed or even irregular stock, it may be required to feed the sheets manually - see page 10 for instructions.



Machine not counting

- Open the exit and remove the blade set (see pages 29-30) to access the dual sensor post located in between the drive rollers. Using a soft brush, clean the visible sensor on the end of the post. Use the brush to clean the sensors between the post and the bottom paper guide which are not visible. Photograph (left) shows the dual sensor post containing the sensors.

No suction

- If the suction drum is not rotating, check all of the drive belts for cleanliness and splits (including the bottom in-feed roller drive belt).

Control panel reads

- **'O-LAP'**

If the machine is 'cutting out' and the control panel reads 'O-LAP', check that the machine is not feeding multiple sheets. If so, check that the paper gate has been correctly set.

- **'h'**

If at any time during the creasing process the control panel displays the letter 'h', it is indicating that the lower blade / anvil has not made contact with the HOME switch ie. Blade still in top position. Switch the machine off and remove the blade set and ensure that the area is free from obstructions. Return the blade set to the creasing unit and switch the machine on. Operate the machine in the normal sequence, if the letter 'h' continues to appear it is advised to contact a Service Engineer immediately.

- **'P'**

If before operating the machine the letter 'P' is displayed on the control panel this indicates that there is an obstruction between the upper sensor assembly and the paper guide sensor (as shown in the above photograph). Switch the machine off and repeat the same procedure as explained above.

Recommended weekly operator maintenance

- Clean all sensors
- Clean in feed rollers and output drive hubs using the Morgana cleaning kit (Morgana cleaning kit part number – 90-018)
- Remove and clean the blade assembly
- With the blade assembly removed, clean the slots and surrounding area within the creasing unit.

Technician Maintenance

It is recommended that your Morgana Documaster is fully serviced at least once every six months by a factory trained Service Engineer.

'Sheets have not cleared from infeed'

Remove sheets from the infeed tray of the Booklet Maker.

'BookMaster Error'

Check all Doors and Access Panels are shut correctly

Check Mains Power is Switched on and also Communication Cable is Plugged in.

Check Waste Bin is Empty.

'Double Sheet Feed' - Detected

Remove any sheets from the infeed tray of the Booklet Maker and also the Suction Drum area.

Ensure integrity of the remaining booklets in the feed stack.

'Overlap - Probable Cause - Double Sheet feed'

Remove any sheets from the infeed tray of the Booklet Maker and also the Suction Drum area.

Ensure integrity of the remaining booklets in the feed stack.

Tighten the paper gate gap and reduce rear air blow.

Run the Job on Pulsed feed not Stream.

ITEM	PART NUMBER	QTY	DESCRIPTION
1	70-060	1	OPERATORS MANUAL (Part 1) (Creasing Unit)
2	70-062	1	OPERATORS MANUAL (Part 2) (Booklet Making Unit)
3	90-018	1	ROLLER CLEANING KIT
4	7-99-01	1	ANVIL SET - Perforator
5	1-99-12	1	PERFORATING BLADE SET - 28T
6	650-040 650-041	1 1	POWER CORD C19 - 3Pin - UK POWER CORD C19 - 3Pin - USA
7	650-016	1	L6 -15P Re-Wirable Plug (Used on USA Only)
8	617-004	4	GLASS BALL - Ø20
9	620-007	1	HEXAGON BALL DRIVER 2mm
10	620-020	1	HEXAGON BALL DRIVER 2.5mm
11	620-026	1	BONDUS L WRENCH 4mm
12	620-028	1	BONDUS L WRENCH 3mm
13	620-033	1	BONDUS L WRENCH 6mm
14	70-055-01	1	BLADE EXTRACTOR TOOL - OP SIDE
15	70-055-02	1	BLADE EXTRACTOR TOOL - LAY SIDE
16	624-018	1	DISPATCH BOX

WARNING.....

THE BLADES FOR ANVIL AND PERFORATING SETS ARE SUPPLIED AS MATCHING PAIRS AND SHOULD NOT BE MIXED OR LEFT UNPROTECTED OR SERIOUS DAMAGE MAY RESULT.

ITEM	PART NUMBER	DESCRIPTION
1	76-213-03	EXTRA NARROW CREASING BLADE SET
2	1-99-12	PERFORATING BLADE SET 28T (Single sheets)
3	1-99-10	PERFORATING BLADE SET 20T (Card)
4	1-99-41	PERFORATING BLADE SET 56T (Fine perforation)
5	1-99-35	ANVIL SET USED WITH ABOVE BLADE SETS

<p>ACCESSORIES.... May be obtained from your dealer and fitted to your machine using the instructions supplied, or by reading your operators manual.</p>	<p>OPTIONS.... May also be obtained and fitted by your dealer. You should not attempt to fit options as specialist tools and knowledge are required.</p>
--	--

PART NO.	DESCRIPTION
607-164	TOOTHED BELT - 430XL
607-165	TOOTHED BELT - 260XL
93-021	FEED BELT
93-022	DRIVE BELT - Vacuum Roller
609-011	Ø RING Ø2 0
609-014	Ø RING Ø1 5
94-028	LOCK PIN ASSEMBLY - Side Lay
79-040-01	HOSE - Air Separation
79-041-01	HOSE - Vacuum
79-042-01	HOSE - Excess Bleed Valve
79-043-01	HOSE - Vacuum Blow
613-137	PLUNGER AND SPRING
613-255	SOLENOID COIL
75-100	SWITCH ASSEMBLY - Set-up
75-098	SWITCH ASSEMBLY - Feed
75-101	SWITCH ASSEMBLY - Rotary Setting Dial
609-013	'O' RING
613-237	CAP - Ø15
613-339	CABLE TIE MOUNTING
613-365	EMERGENCY STOP SWITCH
652-011	SYSTEM SWITCH
613-385	KNOB - Ø15
75-172	CONTROL PCB ASSEMBLY - Documaster
79-002-01	INTERFACE PCB ASSEMBLY
76-230	PAPER GUIDE ASSEMBLY - Bottom Sensor
76-229	PAPER JAM SENSOR ASSEMBLY
76-228	UPPER SENSOR ASSEMBLY
98-012	ANTI-STATIC BRUSH - Autocreaser
609-022	'O' RING Ø32
606-035	KNOB - Roller Tilt
76-109	POWER LINK BEARING
76-213-01	BLADE SET - 320 Wide

PART NO.	DESCRIPTION
76-042	DRIVE BELT - FEED BED - Ø4 POLYCORD
607-042	TIMING BELT 160XL
607-038	TWIN GRIP TIMING BELT - 200 DXL
608-019	SHOULDER BOLT - Adjustment Cams
76-082	PERFORATOR - DRIVE HUB ASSEMBLY
76-083	PERFORATOR - DRIVE WHEEL
76-203-01	INPUT ROLLER ASSY - Upper
76-203-02	INPUT ROLLER ASSY - Lower
76-204	OUTPUT SHAFT ASSEMBLY
78-013	PERFORATOR STRIPPER ASSEMBLY
613-351	MICRO SWITCH - Guard Circuit
613-191	MICRO SWITCH - Home Circuit
75-040	STACKER SWITCH ASSEMBLY
125-01-08	BLACK BOX - STEPPER DRIVE
75-164	LCD DISPLAY MODULE (2x20) & Lead assy
626-004	STATIC ELIMINATOR BAR
120-106	TRANSFORMER ASSY
654-014	ULTRASONIC RECEIVER
654-015	ULTRASONIC TRANSMITTER

NOTE.....

The items listed above represent parts which are subject to wear, loss, or accidental damage, and is included for your guidance only.

Section and item numbers refer to the lists and tables in this manual

Replacement of parts fitted to your machine require specialist knowledge and should therefore be entrusted to your dealer.

PRODUCT RECYCLING & DISPOSAL

European Union

Disposal Information for Commercial Users



Application of this symbol on your equipment is confirmation that you must dispose of this equipment in compliance with agreed national Procedures.

In accordance with European legislation end of life electrical and electronic equipment subject to disposal must be managed within agreed procedures.

Prior to disposal please contact your local dealer or representative for end of life take back information.

Disposal Information for Domestic Users



Application of this symbol on your equipment is confirmation that you should not dispose of the equipment in the normal household waste stream.

In accordance with European legislation, end of life electrical and electronic equipment subject to disposal must be segregated from household waste.

Private households within EU Member States may return used electrical and electronic equipment to designated collection facilities free of charge. Please contact your local disposal authority for information.

In some Member States when you purchase new equipment your local retailer may be required to take back your old equipment free of charge. Please ask your retailer for information.

Other Countries

Please contact your local waste authorities and request disposal information.