

Morgana DocuMaster

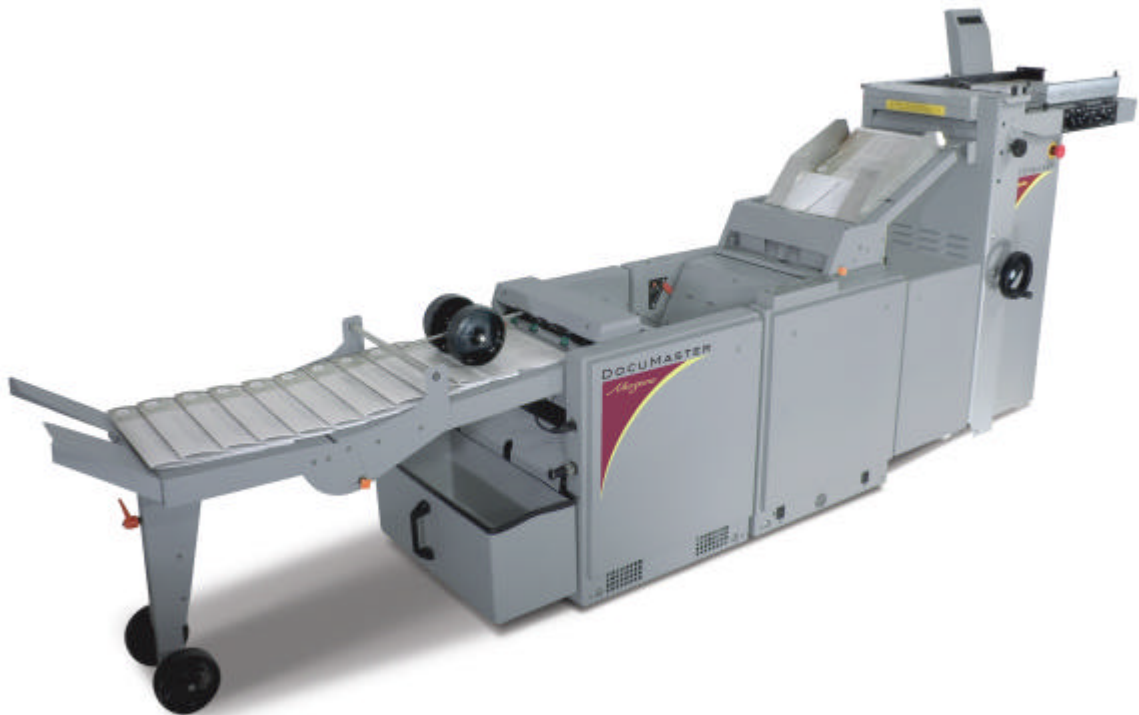

DOCUMENT CREASING & AUTOMATIC BOOKLET MAKING MACHINE

OPERATORS MANUAL (Part 2) **(Booklet Making Unit)**

Morgana Systems Limited United Kingdom
Telephone: (01908) 608888 Facsimile: (01908) 692399
Website: www.morgana.co.uk

ISSUE 1

JUNE 2005

70-062

Specifications	1
Introduction	3
Quick Start	9
Using the Control Panel	11
Booklet Making	17
Edge & Corner Stapling	21
Edge Stapling & Folding	23
The Staple Heads	25
Troubleshooting Chart	29
Maintenance	33
Appendices	
Connecting the TMP	37
Staple Position Adjustment	39
Sharpening the TMP Blade	41
Conveyor Clamp Adjustment	47
Index	51

Intended Use This product is intended to be used for the stapling, folding and trimming of materials as specified.

Operating Conditions 10-35°C at 35-85% relative humidity

Production up to 2,500 per hour

Specifications

Maximum Input Size 482 x 320mm, 18.9 x 13.78"

Minimum Input Size 210 x 140mm, 8.27 x 5.5"

Max Staple Pitch 138mm, 5.4"

Min Staple Pitch 115mm, 4.5"

Maximum Book Thickness 22 Sheets (80gsm)

Maximum Trim 25mm, 1"

Electrical

Voltage 115V, 60 Hz or
230V, 50 Hz
Single Phase
(earthed supply required)

Power (115V) 150VA exc. TRIM
500VA inc. TRIM
20VA Stand-by

Power (230V) 200VA exc. TRIM
700VA inc. TRIM
30VA Stand-by

Current 4.4A (115V) or
3.0A (230V)

Dimensions

BookMaster Pro (W,D,H)	546, 495, 595mm, 70kg 21.5, 19.5, 23.4", 154.3lb
BookMaster Pro with Motorised Infeed (W,D,H)	546, 830*, 840mm**, 79kg 21.5, 32.7, 33.1", 174.2lb
TrimMaster Pro (W,D,H)	546, 650, 595mm, 85kg 21.5, 25.6, 23.4", 187.4lb
Outfeed Conveyor (W,D,H)	404, 1050, 720mm †, 17kg 15.9, 41.3, 28.4", 37.5lb

*Depth without paper tray is 710mm (28.0").
**Height with infeed tray in normal operating position.
†915mm (36") with TMP.

Noise 74dB (A)

Production may vary according to operating conditions.

In linewith a policy of continual product improvement, the manufacturer reserves the right to alter the materials or specification of this product at any time without notice.

Radio Frequency Emissions

This equipment has been tested and found to comply with the limits for a Class A digital device, pursuant to part 15 of the FCC Rules. These limits are designed to provide reasonable protection against harmful interference when the equipment is operated in a commercial environment. This equipment generates, uses and can radiate radio frequency energy and, if not installed and used in accordance with the instruction manual, may cause harmful interference to radio communications. Operation of this equipment in a residential area is likely to cause harmful interference in which case the user will be required to correct the interference at his own expense.

WARNING!

The TrimMaster Pro unit contains a motorised guillotine. It is therefore essential that due care is taken and the operating instructions adhered to when using the unit. Also pay particular attention to any specific warnings given.

The Morgana BookMaster Pro and TrimMaster Pro have been designed to staple, fold and trim booklets of up to 22 sheets, in a wide range of paper sizes. Their modular design means that they are equally at home being used offline, or online with a Watkiss Collator. For offline use, a Motorised Infeed unit is recommended, although a manual Infeed Guide is also available.

The BookMaster Pro and TrimMaster Pro units are also compatible with other manufacturers' bench-top and table-top collators.

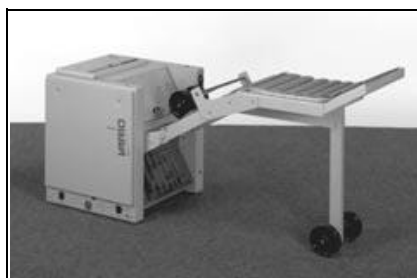

FIGURE 1
BMP with Outfeed Conveyor



FIGURE 2
BMP with Motorised Infeed and
Outfeed Conveyor



FIGURE 3
BMP, TMP and Outfeed
Conveyor (Motorised Infeed
can be fitted also)



FIGURE 4
BMP with manual Infeed Guide

The instructions that follow include the set-up and operating procedure for the BookMaster Pro, the TrimMaster Pro and the Motorised Infeed units. Please ignore those parts of the instructions that do not apply to your configuration.

In these instructions the BookMaster Pro is referred to as the BMP and the TrimMaster Pro is referred to as the TMP.

INSTALLATION

It is recommended that your BookMaster Pro and TrimMaster Pro are sited on a level floor.

Important

This machine must only be plugged into an electrical supply line of the correct voltage and with a proven earth. Any damage caused by failure to do so will not be covered by the warranty. The required machine voltage is shown on the label on the rear of the unit (see Figure 5).

SAFETY FIRST

Your BookMaster Pro and TrimMaster Pro units have been designed with safety as a key feature and incorporate safety covers which, when opened, will automatically cut the power to moving parts. However, as with all electrical equipment, when changing fuses or carrying out operations other than those detailed in this book:

Always first disconnect the machine from the mains electricity supply.

SWITCHING ON Plug in the BMP unit to a single phase power supply of the correct voltage as indicated by the mains input (see Figure 5).

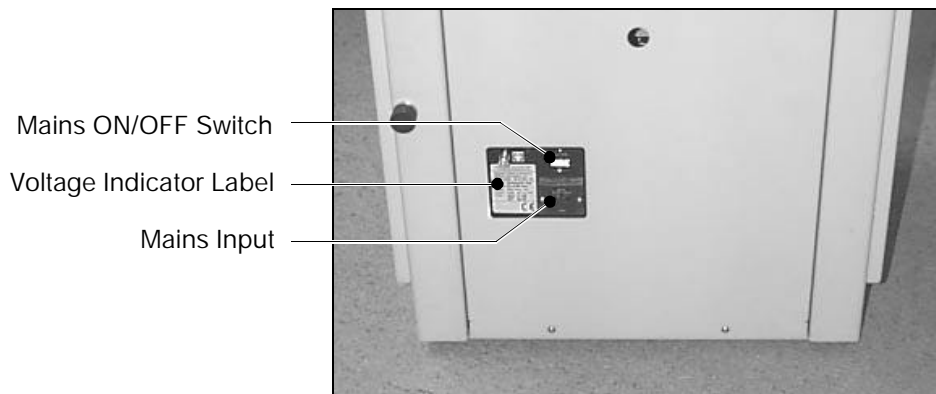

FIGURE 5

Also ensure the outfeed conveyor cable is connected to the socket on the BMP (see Figure 6). If the TMP is installed, ensure that this too is connected (see p. 37).

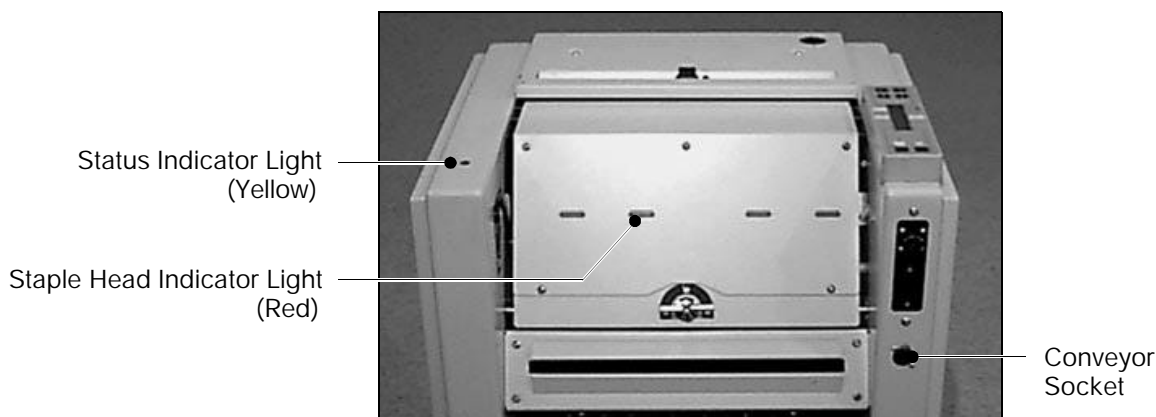

FIGURE 6

MOTORISED INFEED An optional Motorised Infeed (P/N 041-571) is recommended. This fits on to the BMP infeed and makes offline use easier. A paper tray (see Figure 7) is supplied with the Motorised Infeed.

An alternative is the BookMaster Infeed Guide, P/N 041-572 (see Figure 4)

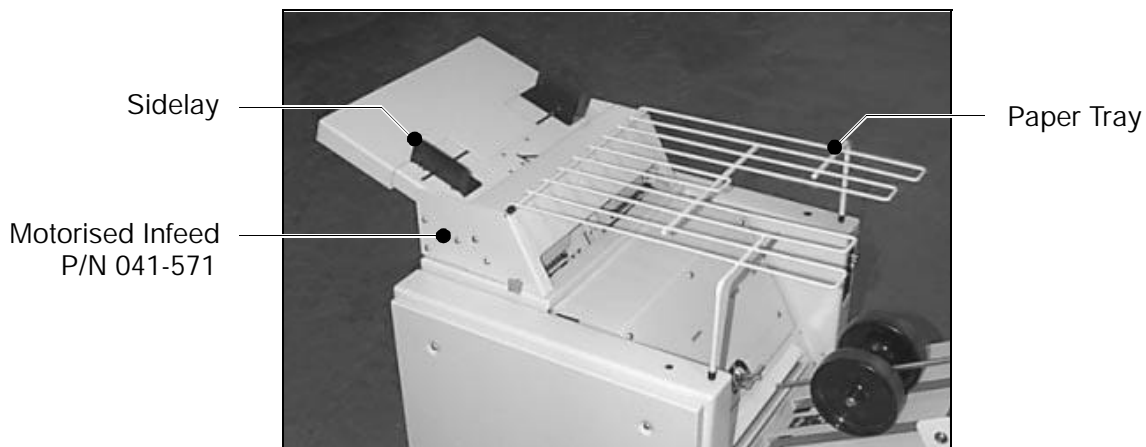

FIGURE 7

Fitting the Motorised Infeed

Loosen the two hand screws (see Figure 8) on either side of the Motorised Infeed.



FIGURE 8

Connect the Motorised Infeed interface cable to the socket on the top of the BMP (see Figure 9).

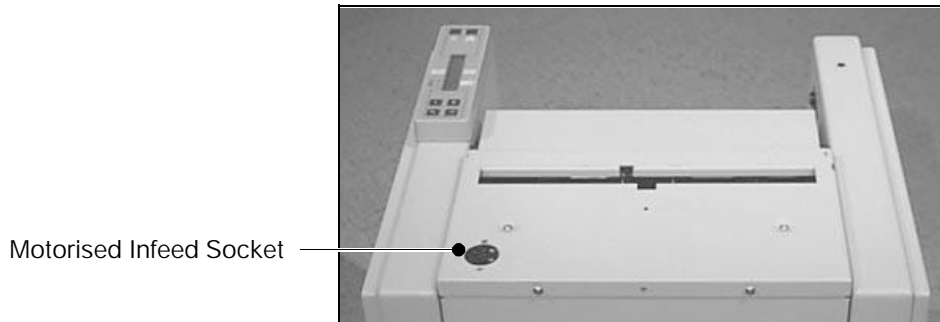

FIGURE 9

Position the Motorised Infeed on the BMP, so that the fixing clips (see Figure 8) locate inside the BMP infeed.

Fit the rear hand screw (see Figure 10) and then tighten the two side hand screws.



FIGURE 10

Fit the paper tray (see Figure 7) if required.

The BMP will automatically start when a set of sheets is fed into the Motorised Infeed. The BMP will automatically stop approximately 10 seconds after the last feed, and return to the standby mode.

The Motorised Infeed will only feed the next set when the BMP is ready.

Status Indicator Light

The yellow indicator light on the BMP (see Figure 6) shows the status of the unit.

Indicator Light Mode	BMP Status
Blinking once per second	The unit is ready to run
Constantly illuminated	The unit is running
Blinking rapidly	There is a jam or other error
Not illuminated	BMP/TMP lid is open, paper is stuck in the paper path or the unit is not switched on

Staple Head Indicator Lights

The red indicator lights on the BMP lid (see Figure 6) show the status of the corresponding staple head.

Indicator Light Mode	Staple Head Status
Blinking once per second	The staple cartridge is about to or has run out
Constantly illuminated	The staple head is selected and ready to run
Blinking rapidly	There is a staple head jam or other error
Not illuminated	The staple head is not selected

Note: Imperial measurements and standard US paper sizes are available (see p. 12).

This section is intended only as a brief operating guide. More complete instructions are included in later chapters.

Change Paper Sizes

One-touch size change is available for the two most common sizes, simply press the appropriate button on the control panel (see p. 13).

Three standard sizes are available through the size menu: **A3>A4 A4>A5 A5>A6**. Access this via the top-left button from the main menu (see p. 13).

Custom sizes can be entered using the top-centre (sheet length) and top-right (sheet width) options on the main menu (see p. 13).

Up to five custom job settings can be loaded into memory. Access these with the **rJOB I** menu (see p. 15).

Select Staple-fold or Edge Staple

Using the lever on the BMP (see p. 21), select the mode of operation you require; either staple-fold or edge staple.

Adjust the Staple Heads

If required, adjust the position of the staple heads and clinchers (see p. 26).

Adjust the Outfeed Conveyor

Slide the large payout wheels up or down their mounting rail so that they are just nipping the spine of the book when it is released from the rollers.

Adjust the Fold Roller Gap

Using the lever on the front of the BMP, set the gap between the fold rollers to suit the set size (see p. 17).

Using the Motorised Infeed

Adjust the Motorised Infeed sidelays (see Figure 7) to the correct sheet width. The sidelays should just touch the sheets but not hold them.

Place the sheets into the Motorised Infeed. The BMP will automatically start, and will stop approximately 10 seconds after the last feed.

The Motorised Infeed will only feed the next set when the BMP is ready.

Check the Adjustments

To check that all the adjustments are correct, feed a set into the unit.

Starting the Job

Once you are happy with the job settings, continue to feed sets one at a time into the Motorised Infeed. Do not feed the next set until the previous set is clear of the Motorised Infeed.

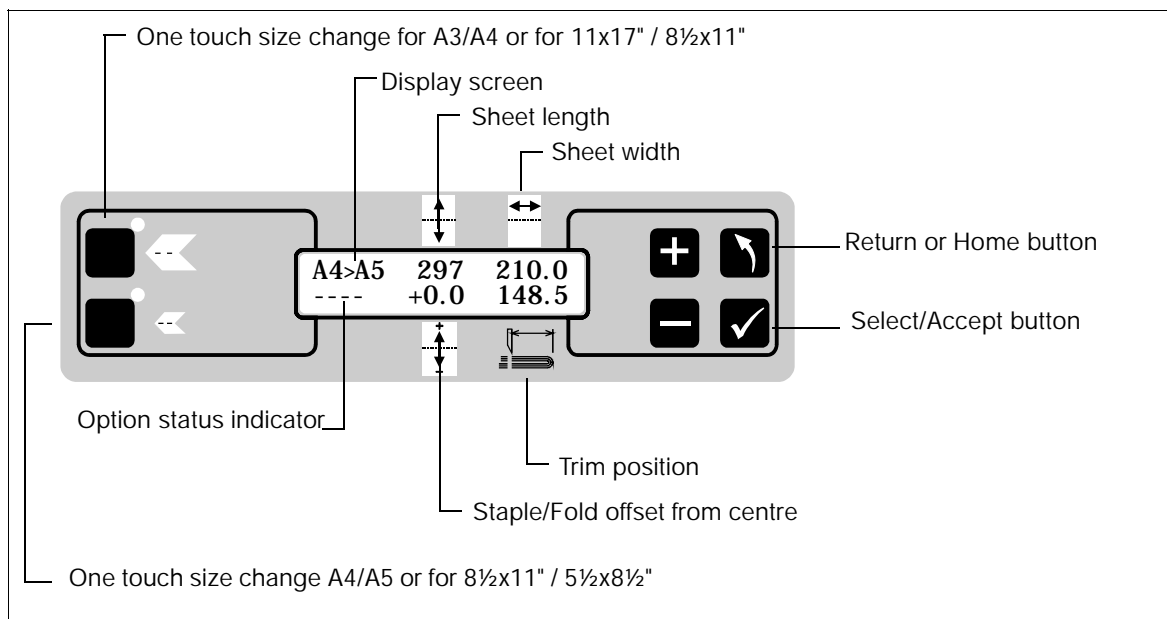

FIGURE 11 BMP Offline Control Panel (metric measurements shown)

NAVIGATION

There are 5 different menu screens. Use **←** and **→** to move between different options on the screen. When an option is selected, it is highlighted by arrows on either side.

eg. r 297 | L

Press **✓** to select the option - this either takes you to another menu screen, or allows alterations to be made.

After selecting an option, press **←** or **→** to make alterations, followed by **✓** to accept the changes.

At any time press **ESC** to return to the main menu.

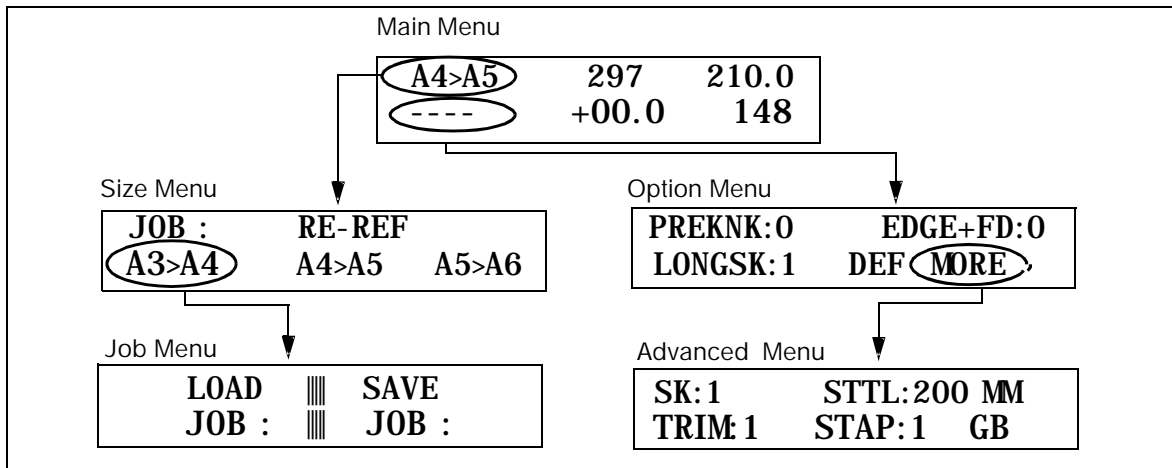

FIGURE 12 BMP Offline Control Panel Menus

PERSONALISING YOUR BMP

Language

To change the language of the control panel display:

- press **←** / **→** to highlight **r----- I ***, press **✓**
- press **←** / **→** to highlight **rMORE I**, press **✓**
- press **←** / **→** to highlight **rGB I**, press **✓**
- press **←** / **→** until your chosen language is displayed, press **✓**

Metric/Imperial

To change between metric and imperial measurements:

- press **←** / **→** to highlight **r----- I ***, press **✓**
- press **←** / **→** to highlight **rMORE I**, press **✓**
- press **←** / **→** to highlight **rMMI**, press **✓**
- press **←** / **→** to toggle between **rMMI** and **rINI**, and then press **✓**

When imperial measurement is selected, US standard paper sizes are available.

*The option status indicator, **r----- I**, will contain the letters **P**, **L** or **E** when 'pre-knock', 'long side knock' or 'edge and fold' are selected respectively (see p. 15).

CHANGING PAPER SIZES

One-touch size change

One-touch size change is available for the two most common sizes, simply press the appropriate button. The BMP will give a double beep when it is ready to run.

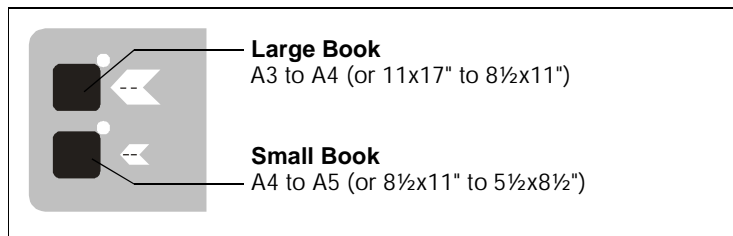

FIGURE 13 One-touch size changes

Standard sizes

Three standard sizes are available through the control panel. Press **[-] / [+]** to highlight the top left position on the screen and press **[✓]**. Press **[-] / [+]** to highlight the standard size needed and press **[✓]**.

Standard Sizes	Input Sheet Size	Booklet size	Trim setting
Metric			
A3 > A4	420x297mm	210x297mm	207mm
A5 > A6	297x210mm	105x148.5mm	145mm
A4 > A5	210x148.5mm	148.5x210mm	102mm
Imperial			
8.5"x11"	11"x17"	8.5"x11"	8.4"
5.5"x8.5"	8.5"x11"	5.5"x8.5"	5.4"
5.5"x4.2"	5.5"x8.5"	4.2"x5.5"	4.1"

Custom sizes

Custom sizes can be entered from the main menu. Press **[-] / [+]** to highlight the required setting and press **[✓]**. Use **[-] / [+]** to increase or decrease the measurement, then press **[✓]**.

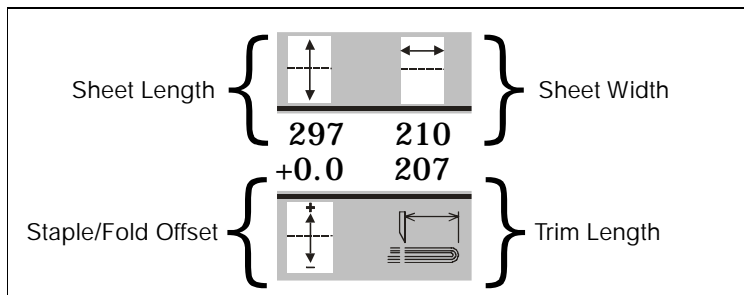

FIGURE 14 Size Adjustment

By default, the staple/fold position will be exactly in the centre of the sheet. This can be altered using the staple/fold offset setting (default is +0.0).

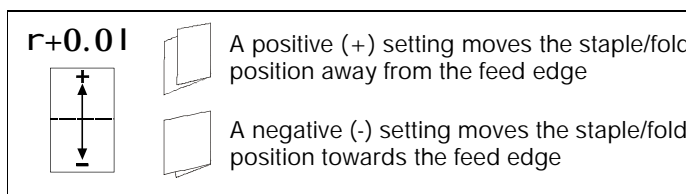

FIGURE 15 Staple/Fold Offset

USING JOB MEMORIES

If required, up to five custom job settings can be loaded into memory, to be retrieved at a later date.

Loading a job

- press **[-]** / **[+]** to highlight the top left position of the screen, press **[✓]**
- press **[-]** / **[+]** to highlight **rJOB1** , press **[✓]**
- press **[-]** / **[+]** to highlight **rLOAD1** , press **[✓]**
- press **[-]** / **[+]** to select the memory required, press **[✓]**

Note: When highlighting an option on the screen, the top left position is always highlighted first, therefore, to access the Job Menu, you can just press **[✓]**, **[✓]**.

Saving a job to memory

- press **←** / **→** to highlight the top left position of the screen, press **✓**
- press **←** / **→** to highlight **rJOB I** , press **✓**
- press **←** / **→** to highlight **rSAVE I** , press **✓**
- press **←** / **→** to select the memory required, press **✓**

CONTROL PANEL OPTIONS

In addition to the functions explained earlier, the following options are also available. When selected, some of these are shown on the 'option status indicator' position on the main menu screen:

PREKNK Selects pre-knock which provides additional jogging prior to stapling. This is useful for heavy or large sheets. When selected, this shows as **P** on the main menu screen.

EDGE+FD When selected, the set will be edge-stapled and then folded. When selected, this shows as **E** on the main menu screen.

LONGSK Selects long side-knock which causes the in-feed sidelays to hold the set during both stapling and folding without releasing. This is useful if the booklet is not being folded square, however it is essential that the sheet width is set accurately. When selected, this shows as **L** on the main menu screen.

DEF Returns the BMP to default factory settings. This does not alter job memories or current size settings.

MORE Enters the 'advanced menu' where additional BMP parameters can be adjusted.

RE-REF If you suspect the BMP adjustment system is not calibrated correctly, you can select this option. After recalibration, the BMP adjustment axes will return to the current settings. If the BMP software detects a possible axis positional fault, the unit will automatically recalibrate the axes.

It is important that you do not re-reference whilst there is paper in the machine, if for example there is a paper jam.

SK Press to adjust the delay between the side-knock and stapling; this is sometimes useful in ensuring a tidy set. The default value is 1. Increase in increments of about 100, up to a maximum of 1000. Note that increasing the side-knock will reduce the production speed of the BMP.

STTL Press to adjust the time delay before folding (the default is 200mS). Reducing the value will increase speed.

TRIM Switches the trim operation on and off.

STAP Switches the staple operation on and off.

SETTING UP THE BMP & TMP

Control Panel

Set the correct paper size, as described in the previous chapter (see p. 13).

Select Centre Stapling

Using the lever on the BMP (see Figure 16), select centre staple operation (lift up).

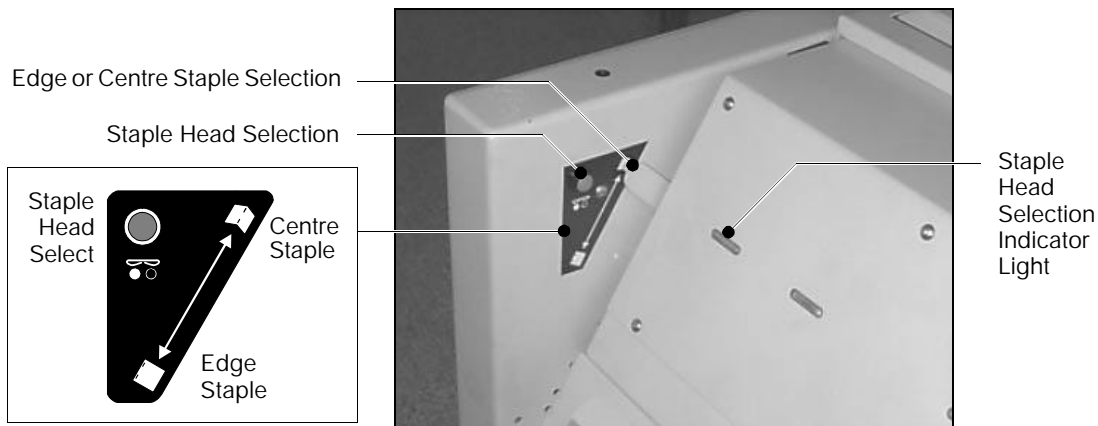

FIGURE 16

Select the Staple Heads

Select the two centre staple heads using the button next to the lever (see Figure 16). The staple head indicator lights show which heads are selected.

The position of the staple heads can also be adjusted. For more details, see page 26.

Adjust the Fold Roller Gap*

The gap between the fold rollers is adjusted using a lever to the left of the front face of the BMP (see Figure 17).

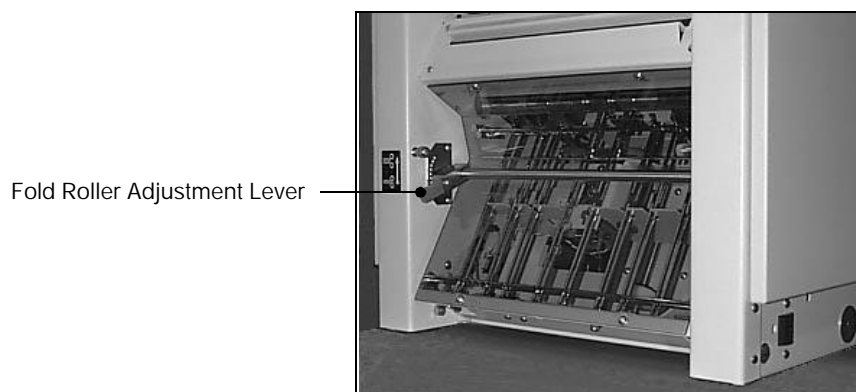

FIGURE 17

The lever has 11 positions. To move the fold rollers further apart (i.e. for larger sets or thicker stock) move the lever upwards. Move the lever down to bring the fold rollers closer together.

The fold rollers should be set sufficiently close together to produce a neat booklet. If the fold rollers are set too close together, the booklet covers may be pulled (resulting in damage around the staples) or the spine of the booklets may be scuffed. Fine-tune the position of the lever to produce the best booklets possible.

Adjust the Outfeed Conveyor

Slide the large payout wheels (see Figure 18) up or down their mounting rail so that they are just nipping the spine of the book when it is released from the rollers. Use the scale on the outfeed as a guide.

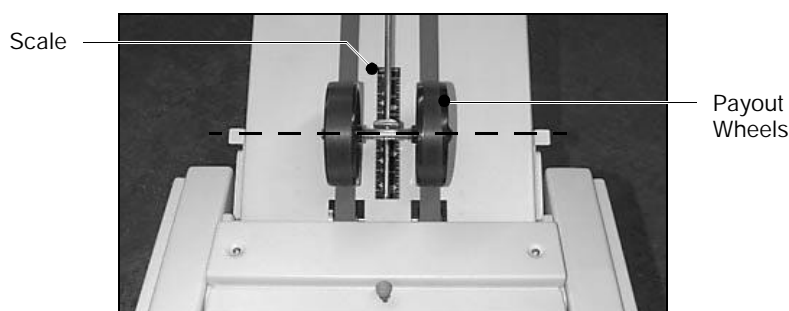

FIGURE 18

The contact point of the wheels should be aligned with the required dimension on the scale, as shown by the dotted line in the photo (see Figure 18). If required, make any fine adjustments once the job is running.

Tip: Common sizes are highlighted on the scale. For example for an A5 (5½ x 8½") book, use the A5 marker.

Hook the trim offcut box (see Figure 19) onto the TMP.

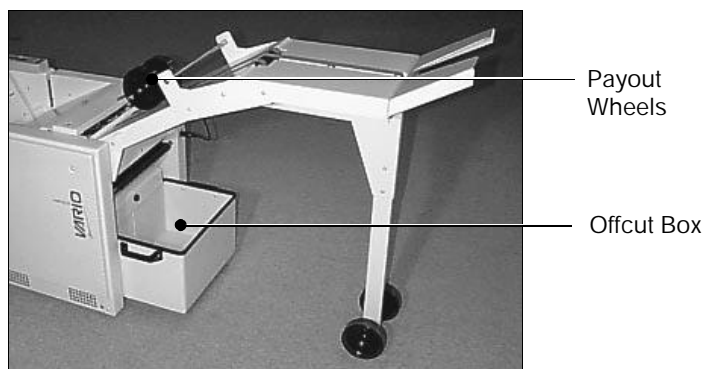

FIGURE 19

Starting the Job

The BMP will automatically start when the first set of sheets is placed into the Motorised Infeed.

Tip: There is a sensor on the TMP to detect when the offcut box is full. Once this sensor is activated, the BMP will beep after every second booklet produced. If you stop feeding sets into the infeed, the BMP will return to standby and beep continuously, until the offcut box is emptied (see Figure 19).

Tip: The BMP can be returned to default factory settings by selecting **DEF**. This does not alter job memories or current size settings.

THIS PAGE IS
INTENTIONALLY
BLANK

Corner stapling is only possible if an optional third staple head is fitted (see Figure 20).

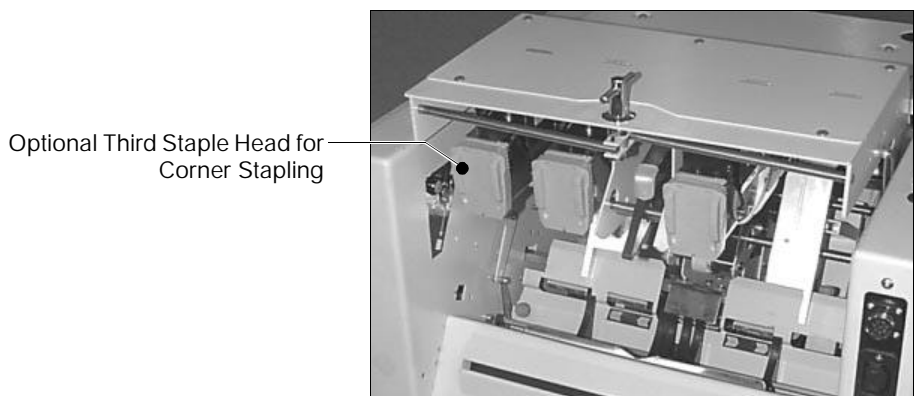

FIGURE 20

ORGANISING THE JOB

Loading the Motorised Infeed

The staples will be inserted into the feed edge of the set. The sheets should therefore be loaded accordingly, i.e. feed the set spine-first into the unit.

Note: The maximum sheet width that can be edge stapled is 250mm, 9.84".

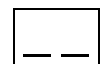

Select Edge Stapling

Using the lever on the BMP (see Figure 21), select edge staple operation (push down).

Note: This will automatically switch off the fold and trim actions.

Select the Staple Heads

Select the required staple heads using the staple head selection button next to the lever (see Figure 21). The staple head indicator lights show which heads are selected.

Note:

For edge stapling, select the two centre staple heads.
For corner stapling, select the third head only.

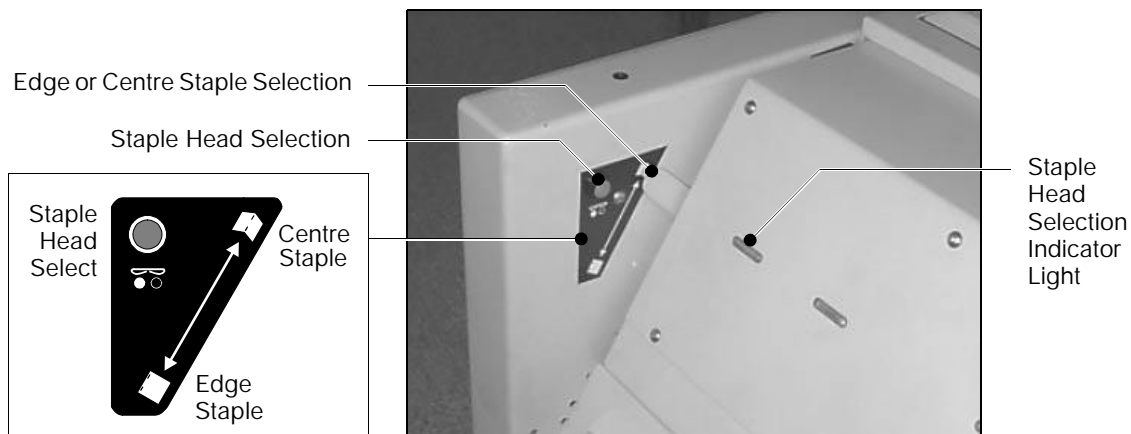

FIGURE 21

Adjust the Staple Heads

If required, open the BMP lid and adjust the position of the staple heads via the lever (see Figure 24 on p.26). Adjust the clinchers to suit.

Adjust the Fold Roller Gap

The gap between the fold rollers is adjusted using a lever to the left of the front face of the BMP (see Figure 17 on p.18).

The Lever should be moved to its lowest position when edge or corner stitching.

Note:

With certain stocks, it is possible that edge-stitched booklets may occasionally jam in the BMP. An edge stitch assistor plate (P/N 907-442) will prevent these Booklets from jamming. The plate is supplied with the optional 3rd stapler head kit (P/N 914-414) and can Also be ordered separately.

If required, it is also possible to edge staple the set and then fold it. The only limitation to this is that the distance from the stapled edge to the fold must be at least half the width of the paper.

Select Edge Stapling and Folding

To enter this special mode, select **EDGE+FD** on the control panel. Using the lever on the BMP (see Figure 16), select centre stapling - not edge stapling (lift up).

Adjustments

Adjust the machine for paper size, as explained previously (see p. 13).

Note: The gap between the fold rollers must be set to suit the set size when edge stapling and folding (see p. 17).

Note: When **EDGE+FD** is selected the trim action is automatically switched off.

Note: The maximum sheet width that can be stapled in this mode is 250mm, 9.84".

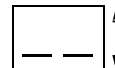

THIS PAGE IS
INTENTIONALLY
BLANK

CHANGING THE STAPLE CARTRIDGES

When a staple cartridge runs out, the corresponding red indicator light (see Figure 22) will blink once per second.

New cartridges are available (P/N 810-022).

To change a cartridge, first open the BMP lid by turning the handle to the left and lifting (see Figure 22). The lid is supported by a strut on the right side.

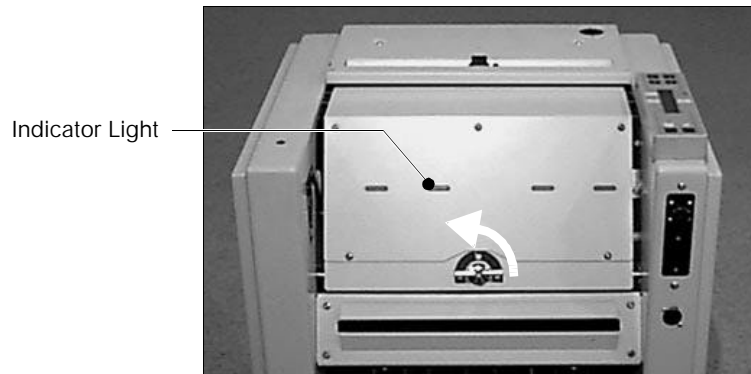

FIGURE 22

Grasp the cartridge at the top and pull directly away from the staple head, as shown by the arrow in the photo (see Figure 23).

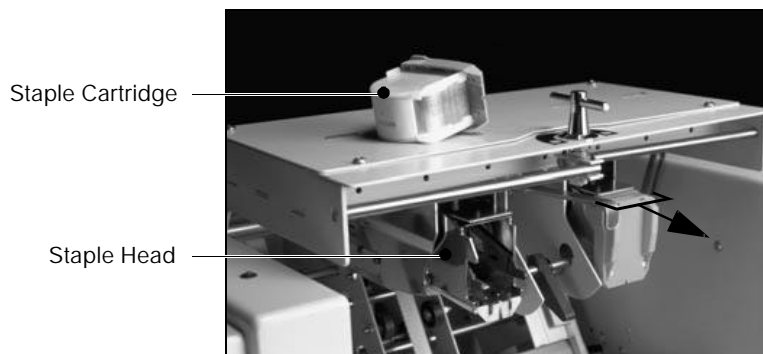

FIGURE 23

Fit the new cartridge and check the machine operation by making a few test booklets.

ADJUSTING THE POSITION OF THE STAPLE HEADS

The staple heads have two positions. Normally the heads should be in the outer position (138mm, 5.4" between staple centres). For small booklets the inner position can be used (115mm, 4.5" between staple centres). Move the lever (see Figure 24) to the right to select the inner position.

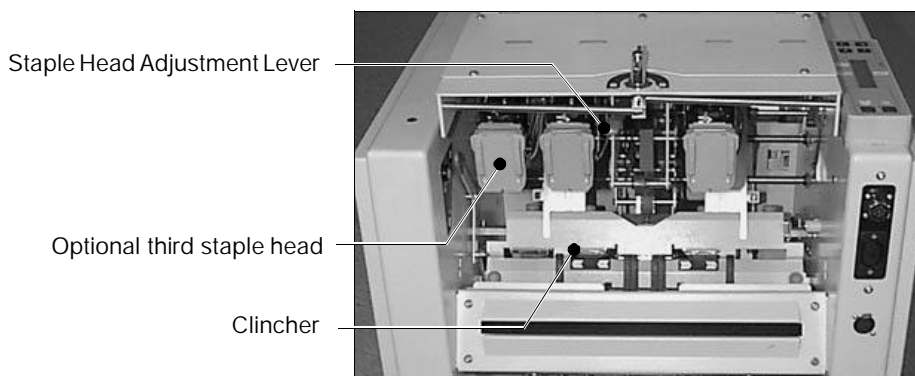

FIGURE 24

When adjusting the staple heads, ensure the staple clinchers are moved to suit. To adjust, loosen the orange hand screw (see Figure 25) and slide the clincher fully across in the required direction. Tighten the hand screw.

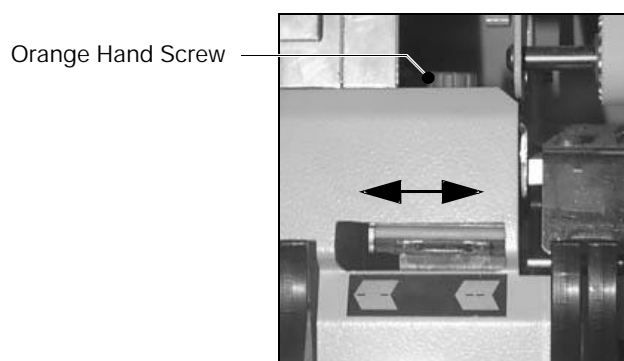

FIGURE 25

Note:

You may have to increase the infeed sidelay gap to access the hand screws. To do this, increase the paper width on the control panel (see p. 13).

Before placing your hands inside the BMP, you should disconnect the unit from the mains electricity supply.

To close the BMP lid, lift it slightly, push the support strut (see Figure 26) and close the lid. Turn the handle to the right to lock in place.

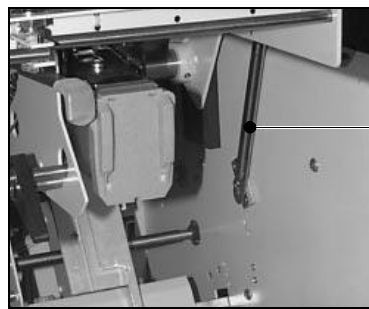

Support Strut

FIGURE 26

THIS PAGE IS
INTENTIONALLY
BLANK

The following is a guideline to help solve any problems or errors, if they persist please call the Morgana Service Department or your Morgana Dealer.

PROBLEM	CAUSE	SOLUTION
Operational Problems		
BMP WILL NOT START	The BMP is not plugged in	Plug into mains connection of the correct type and voltage
	Fuse has blown on the main input	On 220-240V machines there are two 5 amp fuses in the mains input connector, check and replace as necessary. On 115V machines they are 10 amp fuses
	BMP/TMP lid is open	Close the lid
BMP STATUS INDICATOR LIGHT IS BLINKING RAPIDLY	There is a jam or other error in the unit	Clear the jam (see p. 31)
BMP STATUS INDICATOR LIGHT IS NOT ILLUMINATED	BMP/TMP lid is open or unit is not switched on	Close the lid/switch on the unit
BMP BEEPS CONTINUOUSLY	Offcut Box is full	Empty Offcut Box (see p. 19)
ONE OR BOTH STAPLE HEADS ARE NOT ACTIVATED	Staple heads are not selected	Select required staple heads (see p. 17)
	A staple head error has occurred	The heads should self clear. If not, turn the unit off and on again to free the head. If this does not work contact your local Morgana Service Department
FOLD IS NOT ACTIVATED	Unit is in edge staple mode	Move lever into centre staple position (see FIGURE 21 on p.22)
BOOK IS NOT TRIMMED	Trim not selected	Select TRIM on control panel (see p. 15)
	Trim position is set off the edge of the sheet	Reset trim position
	Edge staple or EDGE+FD is selected	Not available in these modes
EDGE STAPLE FUNCTION NOT WORKING	Edge staple not selected	Move lever to correct position and select staple head (see p. 17)
EDGE STAPLED BOOKLETS ARE JAMMING IN THE BMP	Leading edge of booklet is catching the edge stitch deflector shaft	Fit edge stitch assistor plate (see p. 22)

PROBLEM	CAUSE	SOLUTION
STAPLE IS NOT ON THE FOLD	Set is bouncing before stapling	Allow the set more time to settle by increasing SK
	Set is bouncing before folding	Allow the set more time to settle by increasing STTL
	Loose paper or staples in the fold plate area	Locate and remove (see p. 31)
	The infeed sidelays are set too tight	Adjust so that the infeed sidelays barely touch the paper
	EDGE+FD is selected	Deselect EDGE+FD
	Staple position is not adjusted correctly	Fine tune the position of the staples (see p. 39)
FINISHED BOOKLET IS TOO LOOSE	Fold roller gap is too wide	Adjust the fold roller gap (see p. 17)
TOP JOG DAMAGE ON THE SET	The sheet length has been set too short	Adjust the paper input size setting (see p. 13)
	Fold roller gap is too narrow (when edge stitching)	Adjust the fold roller gap (see p. 17)
UNTIDY BOOKLET	Set needs more time to settle before stapling	Allow more time for the set to settle by increasing SK
	The BMP adjustment system is not calibrated correctly	Select RE-REF to manually recalibrate the BMP adjustment axes
BOOKLETS WILL NOT STACK ON THE CONVEYOR	Large payout wheels incorrectly positioned	Reposition (see p. 18)
	Electrical connection is unplugged	Plug in electrical connection between the BMP/TMP and the outfeed conveyor
BOOKLET COVER IS MARKED	Dirty fold rollers	Clean them with a cloth dampened with soapy water or alcohol (isopropanol). Do NOT use blanket wash (see p. 33)
	Fold roller gap is too narrow	Adjust the fold roller gap (see p. 17)
CANNOT CLOSE BMP LID	Support strut is in place	Lift the BMP lid slightly, push the support strut (see Figure 34 on p. 38) and close the lid
BOOKLET IS TRIMMED OUT OF SQUARE	TMP conveyor clamp requires adjustment	See Appendix 4

PROBLEM	CAUSE	SOLUTION
BOOKLETS ARE TRIMMED TOO SHORT	TMP conveyor clamp requires adjustment	See Appendix 4
COVER IS DAMAGED AROUND STAPLES	TMP conveyor clamp requires adjustment	See Appendix 4
	Fold roller gap is too narrow	Adjust the fold roller gap (see p. 17)

Staple Head Problems

ONE OR BOTH LEGS TURN OUT	Incorrect clincher alignment	Re-align (see p. 26)
STAPLE COMES OUT IN PIECES	Staple jammed in the cartridge	Inspect cartridge (see p. 25) and remove any jammed staple wire
	A staple head error has occurred	The heads should self clear. If not, turn the unit off and on again to free the head. If this does not work contact your local Watkiss service department
STAPLE HEAD INDICATOR LIGHT BLINKS ONCE PER SECOND	Staple cartridge empty	Replace cartridge (see p. 25)
STAPLE HEAD INDICATOR LIGHT BLINKS RAPIDLY	A staple head error has occurred	The heads should self clear. If not, turn the unit off and on again to free the head. If this does not work contact your local Watkiss service department

Paper Jams

Paper Jams are most commonly caused by: incorrect settings of the Motorised Infeed sidelays; by paper jammed in the TMP infeed or the conveyor. Other causes include the use of curly paper and staples stuck in the clinchers.

Open the BMP lid (this will disconnect the power for safety) and remove any jammed sets. Check carefully and correct any faulty adjustments that caused the jam to occur (as detailed). If there are staples stuck in the clinchers, remove with a pair of pliers. Paper jams in the TMP can be caused by offcuts obscuring the sensor in the conveyor. The metal conveyor lid (see Figure 29 on p.34) can be opened to remove any jammed sets and trim offcuts.

WARNING: DISCONNECT THE MACHINE FROM THE MAINS ELECTRICITY SUPPLY BEFORE WORKING NEAR THE BLADE AREA

Error Indication

Certain errors are highlighted by the yellow indicator light or the red staple head indicator lights. For more information see page 8.

The BMP and TMP units require only a small amount of routine maintenance.

CLEANING

Build up of set-off powder, ink or general dust will gradually impair the performance of your BMP and TMP. Optimum performance will be obtained by keeping the machine clean.

Fold Roller and Conveyors

Build-up of set-off powder or ink on the fold rollers and conveyor belts will eventually cause slippage or ink transfer.

Warning!

Access to the manual cranking points on the BMP and TMP requires the side covers to be removed. For safety reasons this procedure should therefore only be conducted by authorised personnel. Disconnect the power before removing the side covers.

BMP

To clean the rollers and belts on the BMP, first remove the right hand side cover (two x M5 button screws) to give access to the manual cranking point (see Figure 27).

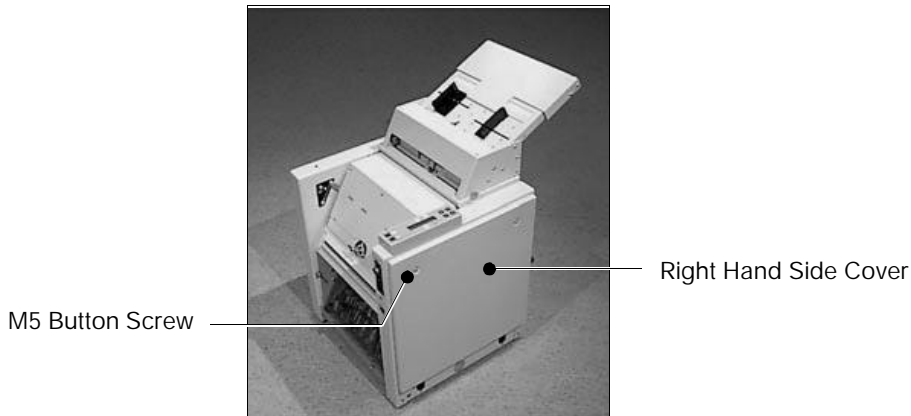

FIGURE 27

Open the BMP lid to access the fold rollers. Using a 10mm A/F spanner (wrench), manually crank the BMP by turning the nut (see Figure 28) clockwise, and clean the rollers.

and belts with a cloth dampened with soap and water or alcohol (isopropanol). Do NOT use blanket wash.

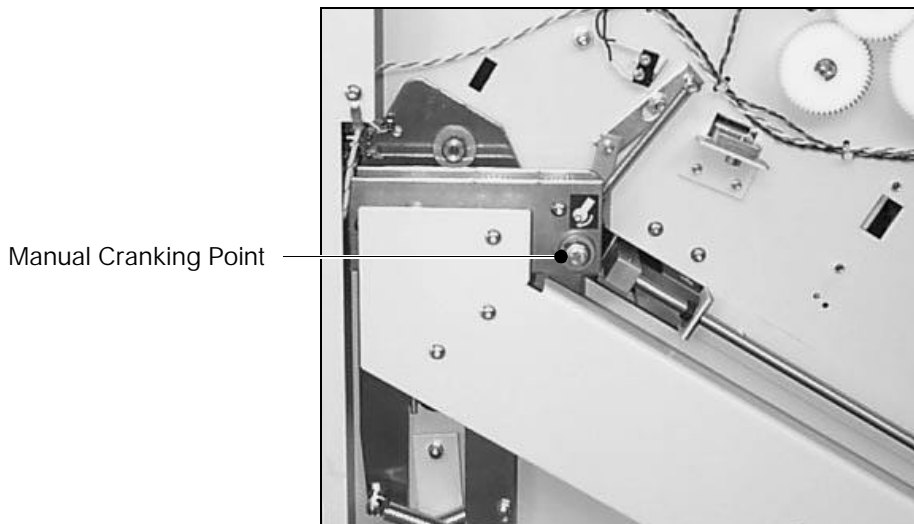

FIGURE 28

TMP

To clean the belts on the TMP, first remove the left hand side cover (two x M5 button screws) to give access to the manual cranking point (see Figure 29).

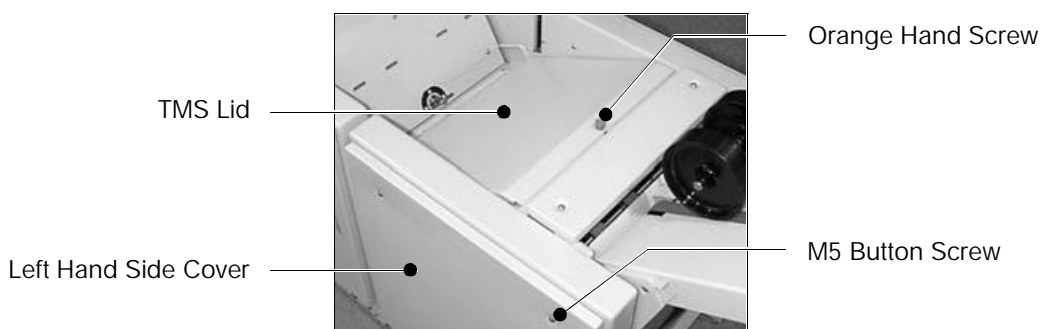

FIGURE 29

Open the TMP conveyor lid (see Figure 29) by lifting the orange hand screw (this doesn't need to be loosened, just use it as a handle).

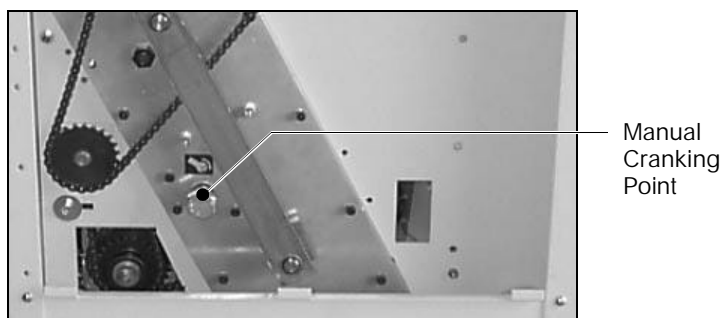

FIGURE 30

Using a 19mm A/F spanner (wrench), manually crank the TMP by turning the nut (see Figure 30) clockwise, and clean the belts with a cloth dampened with soap and water or alcohol (isopropanol).

Do NOT use blanket wash.

Warning!
Ensure that hands are kept clear of the TMP blade area at all times.

TMP BLADE SHARPENING The TMP blade (and anvil) should be sharpened when required (see Appendix 3).

THIS PAGE IS
INTENTIONALLY
BLANK

Procedure

Open the BMP lid by turning the handle to the left and lifting (see Figure 31). The lid is supported by a strut on the right side.



FIGURE 31

Line up the TMP docking plates (see Figure 32) with the BMP. Connect the power and communications cables to the sockets on the BMP.

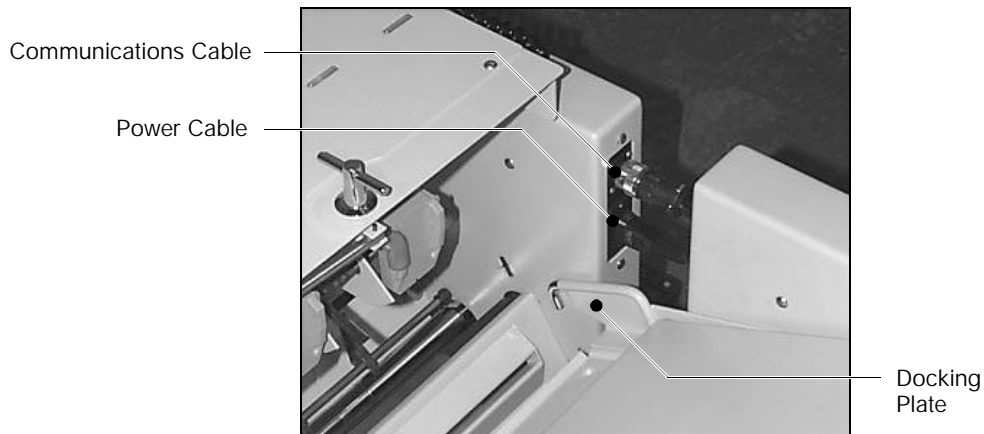

FIGURE 32

Push the two units together so that the hooks on the TMP docking plates align with the holes in the BMP side plates (see Figure 33).

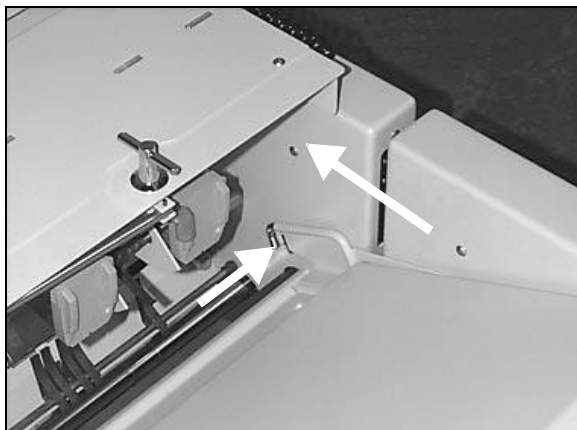

FIGURE 33

Lift the BMP lid slightly, push the support strut (see Figure 34) and close the lid. Turn the handle to the right to lock the TMP in place.

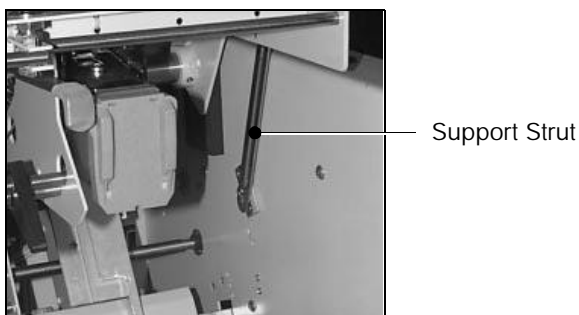

FIGURE 34

Hook the Outfeed Conveyor onto the support posts on the TMP and connect the interface cable.

Tools required
Flat Blade Screwdriver

If both staples are consistently off the spine of the book first ensure that the BMP is adjusted correctly and that delivery into the unit is good. If the problem persists, fine tuning of the staple position may be necessary. Adjustment is via the central screw on the fold plate mechanism, located behind the perspex cover (see Figure 35).

Fold Position Fine Tuning

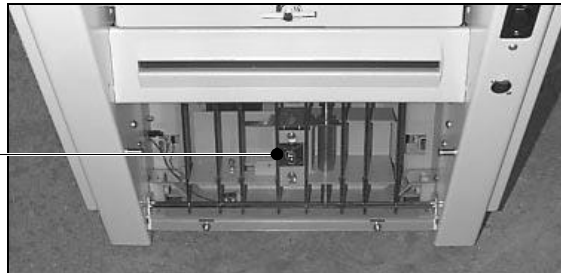
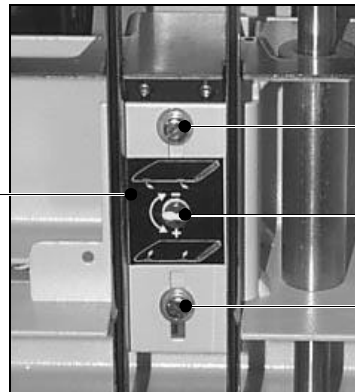
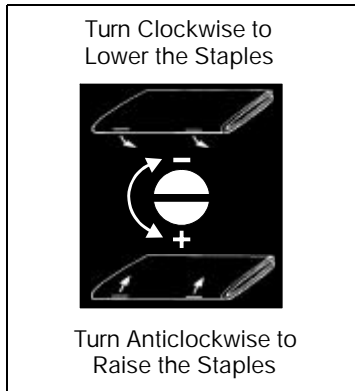

FIGURE 35

If necessary, adjust the fold position until the screws align with the holes in the perspex cover. Using a flat blade screwdriver, loosen the two locking screws (see Figure 36).



Locking Screw

Fine Adjustment Screw

Locking Screw

FIGURE 36

Turn the fine adjustment screw (see Figure 36) clockwise to lower the position of the staples (as viewed when the book exits the unit) and anticlockwise to raise the staples. One quarter turn of the screw equates to approximately 2mm of travel.

Tighten the locking screws and produce a test booklet. Repeat the procedure if necessary.

THIS PAGE IS
INTENTIONALLY
BLANK

The TMP blade and anvil are located behind the conveyor assembly (see Figure 37) at the docking end of the unit.

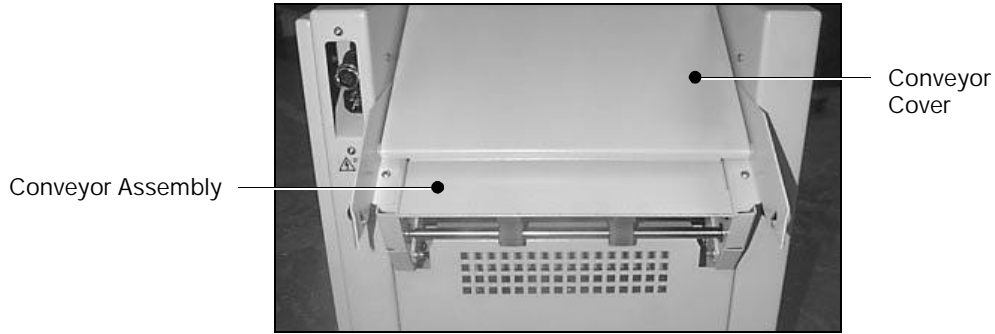

FIGURE 37

Periodically all TMP blades will require re-grinding. Poor grinding will result in poor life, and can cause cracks and nicks in the blade. We therefore offer the guidelines on page 46 which should accompany the blade and anvil when they are sent for regrinding. Whenever the TMP blade is reground, check the condition of the anvil also. This will only require regrinding if it has become damaged.

Warning!
 This procedure is potentially hazardous and should only be conducted by suitably skilled personnel. Disconnect the power before removing the conveyor assembly. Handle the blade with extreme caution and keep hands clear of cutting edges at all times.

Parts Required (if necessary)	Tools Required
TMP/1189 onwards:	3mm allen key
253-835 TrimMaster blade & guide	4mm allen key
TMP/1188 and earlier:	6mm allen key
253-173 TrimMaster blade	10mm allen key
	19mm spanner

Procedure

Separate the TMP from the BMP. Open the TMP conveyor cover (loosen the orange hand nut). Remove the two orange hand screws that secure the conveyor assembly to the TMP unit (see Figure 38).

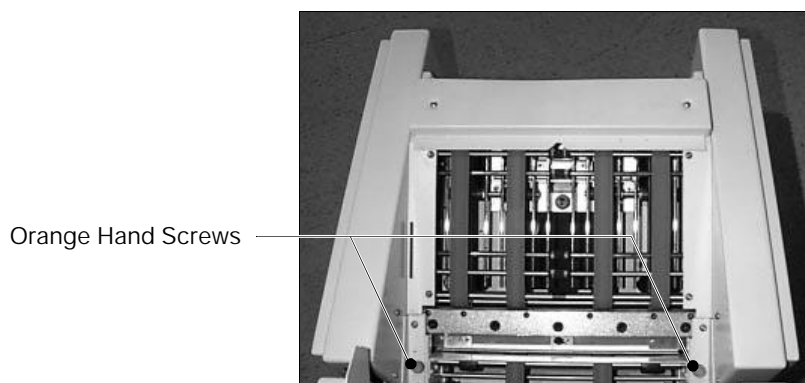

FIGURE 38

Lift away the conveyor assembly to reveal the blade assembly (see Figure 39).

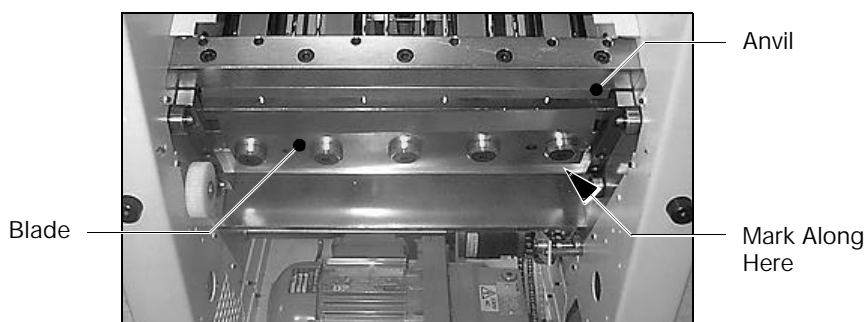

FIGURE 39

Important

Note the angled position of the TMP blade and with a marker pen or similar, mark along the bottom edge of the blade (see Figure 39). This will act as a guide when refitting.

Removing the TMP Blade

Slightly loosen all five blade fixing screws (see Figure 40). Remove the outer two screws and screw them into the locator holes. These will now act as handles. Remove the remaining screws and carefully lift the blade away. Immediately put the blade away safely.

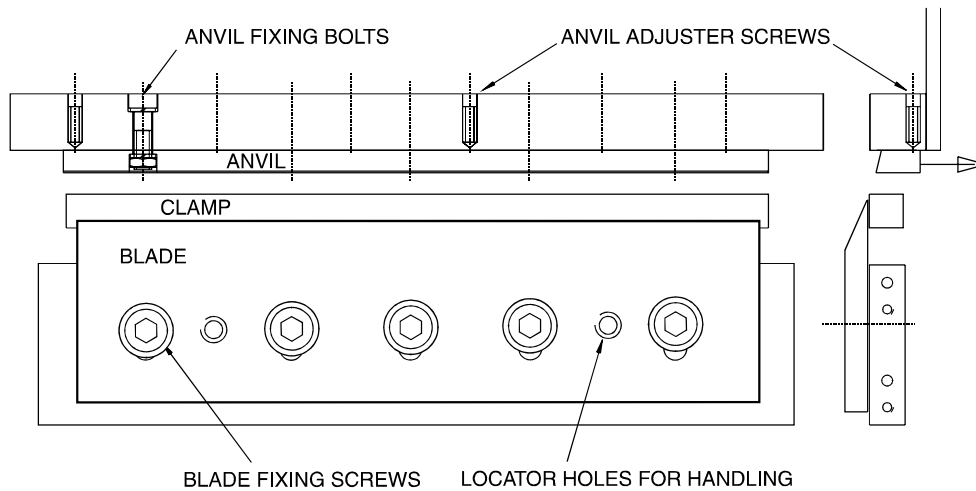

FIGURE 40

Check the anvil

Carefully check the anvil for any damage. If it requires regrinding, remove the five fixing screws and lift away.

Refitting the TMP blade and anvil

Slacken the anvil adjuster screws back two revolutions. Position the anvil fully back towards the conveyor and lightly tighten the anvil fixing screws. Affix the blade using the five blade fixing screws but do not tighten. Using the mark made when the blade was removed, adjust the angle of the blade. Ensure that it does not protrude above the clamp at point 'A' or below it at point 'B' (see Figure 42). Lightly tighten the centre screw, sufficient to hold the blade in this position.

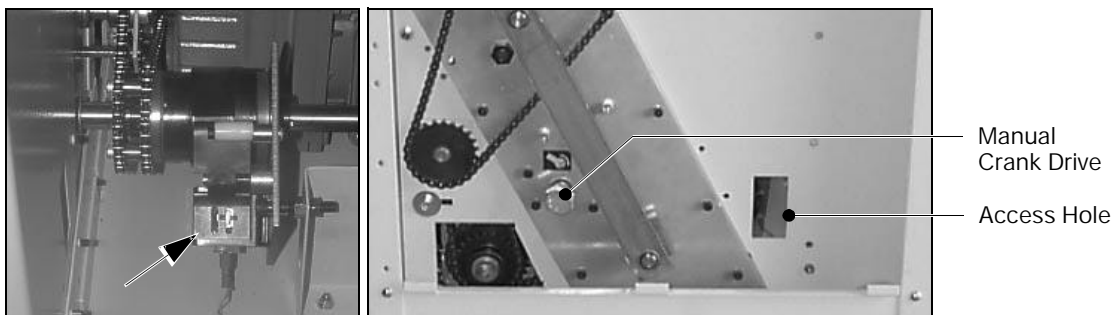

FIGURE 41

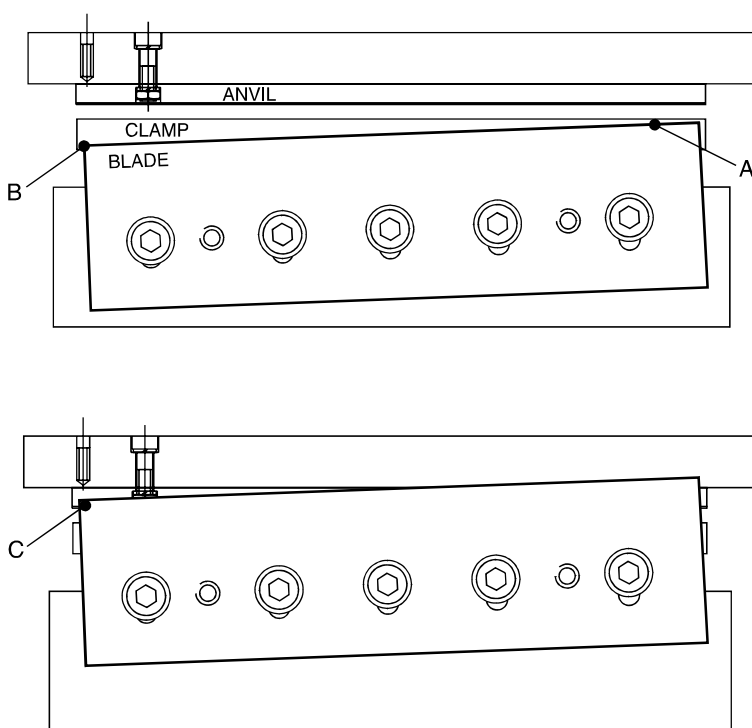

FIGURE 42

Remove the left hand TMP side cover (two x M5 button screws and washers). Release the clutch by depressing the lever (see arrow) through the access hole in the side plate (see Figure 41). Use a 19mm spanner to manually crank the unit until the blade is at top dead centre. At point 'C' (see Figure 42) the blade must pass the anvil by 1mm (1/25"). Make fine adjustments to the position if necessary. Tighten all the blade fixing screws starting from the centre and working out. Push the anvil firmly forwards against the blade (pushing from behind with your fingers at each end). Maintain a light pressure on the back of the anvil whilst tightening the anvil fixing bolts starting from the centre and working out. Lightly tension the anvil adjuster screws against the anvil.

Final adjustment

Release the clutch and manually crank slowly several rotations to check that the blade passes the anvil smoothly without obstruction.

Place a single sheet of paper (large sheet size) between the blade and the anvil and manually crank to produce a test cut.

Warning!

Ensure that hands are kept clear at all times.

Check that a clean cut is obtained across the full width of the blade. If necessary loosen the anvil fixing screws at the point where adjustment is needed, apply additional pressure to the anvil adjusting screws (1/6th turn at a time) and re-tighten the anvil fixing screws.

Perform another test cut and make further adjustments if necessary.

Hook the conveyor assembly onto the support posts and push into position. Secure with two M5 button screws and washers (see Figure 38).

Fit the side cover and secure.

TrimMaster Blade Grinding Instructions

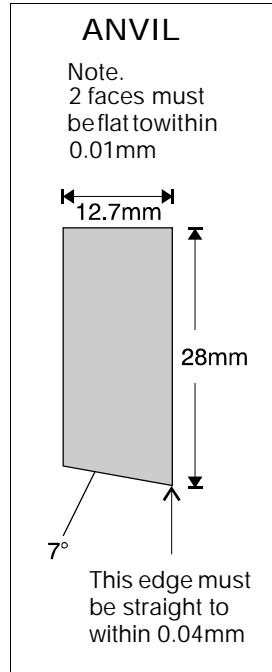
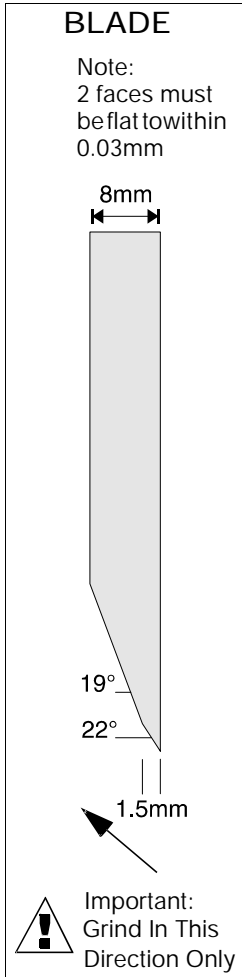

Note: TrimMaster blade 253-835 is fitted with a guide leg. This **must** be removed when the blade is reground and refitted afterwards.

- Blade Material High Carbon High Chrome (Aisi D2/D3)
- Grinding Angle See drawing alongside
- Grinding Wheel Cup or Cylinder
- Grinding Material Grit : 46-60
Hardness : G-H
Bond : Vitrified
- Peripheral speed of the grinding wheel 20-26 (V M/S)
65-85 (V Ft/S)
- Table Speed 20-26 (V M/Min)
65-85 (V Ft/Min)
- Feed per pass 0.01 - 0.02mm
0.0004 - 0.0008"

Honing

After re-grinding, the burr should be carefully removed by honing. The quality of honing affects the useful life of the cutting edge.

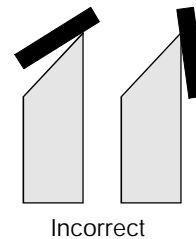
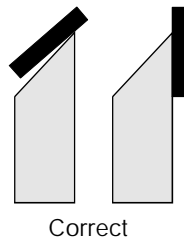

The TMP conveyor clamps are set to a default position at the factory, which gives a good trim over a wide variety of booklet thicknesses.

However, when trimming unusually thick or thin booklets, the conveyor clamps may need to be adjusted.

If the conveyor clamps are set too loose, the booklet may not be delivered correctly to the trim stop, or it may bounce against the trim stop. This will result in the following problems:

- booklets are trimmed out of square (this may also indicate that the left and right conveyor clamps are set unevenly).
- Booklets are trimmed too short.

If the conveyor clamps are set too tight, the following problem may occur:

- The cover of the booklets are pulled, resulting in damage around the staples.

Tools required
4mm allen key
2 off 150mm/6" rule

Procedure

On the BMP control panel, set the paper size to **A4>A5** (regardless of the booklet size). Once the BMP beeps to confirm it is ready, disconnect it from the mains.

Open the TMP conveyor cover, by lifting the orange handscrew (see Figure 43).

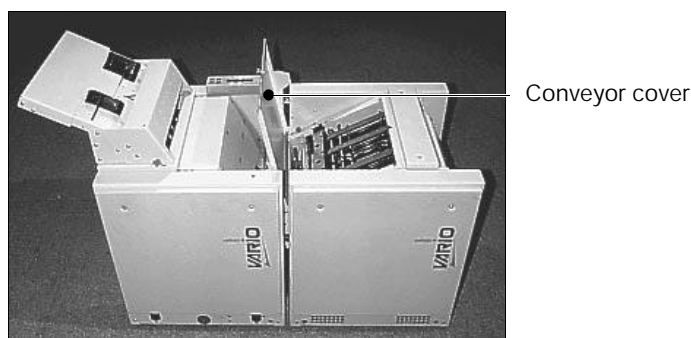

FIGURE 43

There are two clamp roller shafts, which are adjusted using a 4mm allen key (see Figure 44).

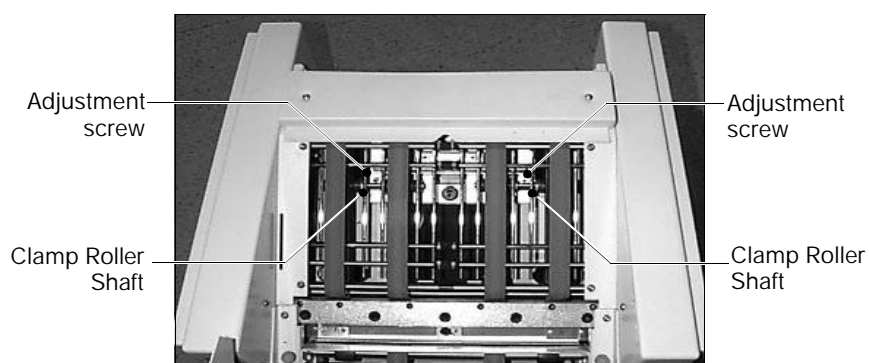

FIGURE 44

Adjusting the Conveyor Clamps

To adjust the conveyor clamp:

- Turn the adjustment screws clockwise to increase the gap (reducing clamp pressure)
- Turn the adjustment screws ant-clockwise to reduce the gap (increasing clamp pressure)

Checking the adjustments

It is important that both clamp roller shafts are adjusted to the same height. The factory default is 17mm between the top of each shaft and the top of the wire frame.

When making any adjustments, you must re-measure the height of both shafts, to ensure they are set the same. The easiest way to do this is:

- Lay the first rule across the wire frame, so that it is above the clamp roller shaft (see Figure 45)
- Using the second rule, measure the height from the top of the shaft to the bottom of the first rule
- Adjust the shafts as necessary to ensure they are both set to the same height

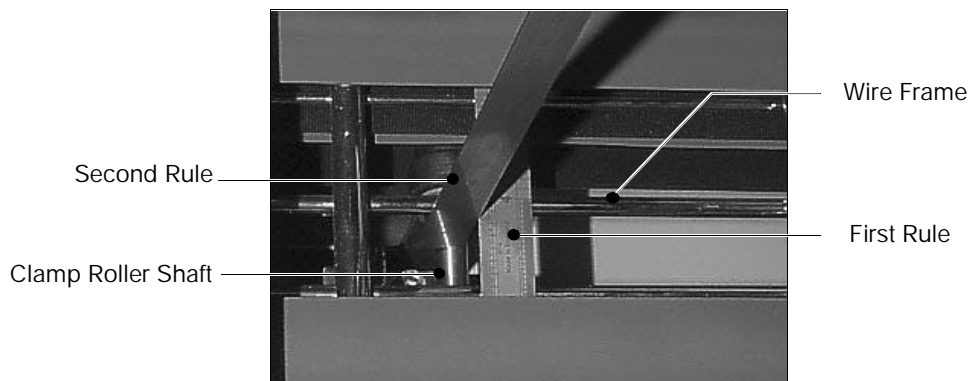

FIGURE 45

Restarting the job

Before restarting the job, don't forget to reset the paper size as necessary.

Note:

It is important to return both clamp roller shafts to the factory default height of 17mm before booklets of a more typical thickness are produced.

THIS PAGE IS
INTENTIONALLY
BLANK

- A**
 - adjustable fold rollers 17
 - adjustment axes, re-referencing 15
 - adjustment of conveyor clamp 47–49
- B**
 - blade sharpening, tmp 35
 - booklet making 17–19
 - setting up the bmp 17–19
- C**
 - centre staple selection 17
 - clamp roller shafts 48, 49
 - connecting the tmp 37–38
 - control panel 11–16
 - menu navigation 11
 - conveyor clamp adjustment 47–49
 - corner & edge stapling 21–22
- D**
 - default settings 15
 - dimensions 2
 - docking plates, tmp 37
- E**
 - edge & corner stapling 21–22
 - edge and fold 15
 - edge stapling & folding 23
 - errors - see troubleshooting
- F**
 - Fold rollers, adjustable 17
- G**
 - getting started 9
- I**
 - infeed - see motorised infeed
 - installation 4
 - introduction 3–8
- J**
 - jams 31
 - job memories 14
- L**
 - language 12
 - long side-knock 15
- M**
 - maintenance 33–35
 - cleaning the units 33
 - manual cranking point, bmp 33
 - manual cranking point, tmp 34
 - motorised infeed
 - fitting the motorised infeed 6
 - using the motorised infeed 9, 21
- O**
 - offcut box 19
 - outfeed conveyor adjustment 9, 18
- P**
 - paper jams 31
 - paper sizes 9, 13
 - payout wheels adjustment 18
 - power supply 1
 - pre-knock 15
- Q**
 - quick start 9
- R**
 - radio frequency emissions 2
- S**
 - safety 4
 - setting up the bmp 17–19
 - centre staple selection 17
 - control panel 17
 - outfeed conveyor adjustment 9, 18
 - trim offcut box 19
 - settle 16
 - side stapling 21–22
 - side-knock 16
 - specifications 1
 - standard paper sizes 13
 - staple cartridges, changing 25
 - staple head indicator lights 8
 - staple heads 25–27
 - adjusting 26
 - clinchers 26
 - selecting 21
 - staple cartridges, changing 25
 - switching off 16
 - staple position fine tuning 39
 - starting - quick set-up 9
 - status indicator light 8
 - switching on 4
- T**
 - tmp blade sharpening 41–46
 - final adjustment 45
 - honing 46
 - refitting the blade and anvil 43
 - removing the blade 43
 - trim 16
 - trim offcut box 19
 - troubleshooting 29–31
 - operational problems 29
 - paper jams 31
 - staple head problems 31
- U**
 - using the control panel 11–16

