

Morgana DigiCreaser

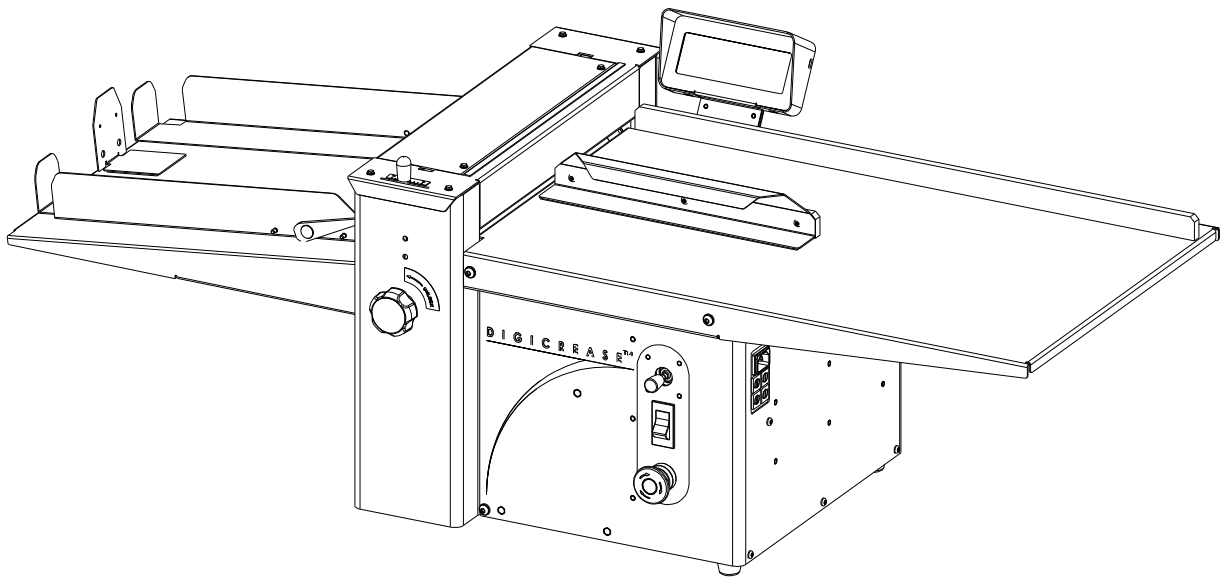

HAND FED DOCUMENT CREASING MACHINE

ILLUSTRATED PARTS MANUAL

Morgana Systems Limited United Kingdom

Telephone: (01908) 608888 Facsimile: (01908) 692399

Website: www.morgana.co.uk

ISSUE 5 NOVEMBER 2011

70-086

Morgana **DigiCreaser**

ILLUSTRATED PARTS MANUAL

The Illustrated Parts Manual has been designed to assist when selecting a part or assembly which may be required to service or repair your machine.

The index on page four lists all of the major assemblies in the order in which the machine is constructed.

The following page demonstrates how to recognise a part from a sub-assembly and shows the quantity contained within the major assembly.

The major assembly number and description is listed at the top of the page and should always be quoted when ordering parts or when seeking technical advice.

Before ordering parts confirm that the model number of the machine (listed at the top of page four) is identical to the number stamped on the specification plate fixed as shown in section two (starting page 6). Whilst checking this, make a note of the serial number also stamped on the plate.

Some components will not be made available individually as they form part of sub-assembly which may require specialist tools and knowledge to dismantle. The machine may not perform correctly if attempts are made to repair sub-assemblies of this type.

NOTE....

**ALWAYS READ THE OPERATORS MANUAL BEFORE MAKING ANY
ADJUSTMENTS TO YOUR MACHINE AND ALWAYS DISCONNECT THE POWER
SUPPLY BEFORE REMOVING ANY COVERS.**

USING THIS MANUAL.....

CIRCLED ITEM NUMBERS IN LISTS & ON ILLUSTRATIONS INDICATE SUB ASSEMBLIES.

ITEMS LISTED ARE AVAILABLE INDIVIDUALLY AS SPARE PARTS.

10			
11	92 - 039	1	SLIDE FRAME ASSEMBLY - Low
12	95-046	1	SWITCH ASSEMBLY - Set-up
13	95-047	1	SWITCH ASSEMBLY - Feed
14	95-049	1	SWITCH ASSEMBLY - Rotary Setting Dial
15	95-058	1	SWITCH ASSEMBLY - Push Button 1
16	95-059	1	SWITCH ASSEMBLY - Push Button 2
17	95-060	1	SWITCH ASSEMBLY - Push Button 3
18	95-064	1	SWITCH ASSEMBLY - Push Button 4
19			
30			

QUANTITY PER ASSEMBLY

NOTE....

Some sections have footnotes to explain various aspects of the parts lists and accompanying illustrations. They may also include warnings about the fitting of parts, their removal, or the need to use special tools.

TIP....

Some sections have tips to assist you in choosing spare parts for your machine or advice about keeping certain parts readily available to minimise downtime.

WARNING.....

SOME SECTIONS HAVE WARNING NOTICES TO ADVISE YOU ABOUT ACTIONS WHICH MAY IMPAIR YOUR MACHINES PERFORMANCE OR CAUSE UNNECESSARY DAMAGE.

SECTION	ASSEMBLY	DESCRIPTION	PAGE
1	7-01-15	MAIN FRAME ASSEMBLY	6
2	7-03-12	FEED BED ASSEMBLY	12
3	7-06-12	CREASING UNIT	14
4	7-08-01	STACKER ASSEMBLY	22
5	75-022-01	MOVING SIDE LAY ASSEMBLY	23
6	770820	FINAL ASSEMBLY	24
7	7-05-14	OPTIONAL FLOOR STANDING BASE	26

NOTE....

TIP....

To assist you in quickly finding the section you require, there are numbered tabs positioned down the outside edges of each page.

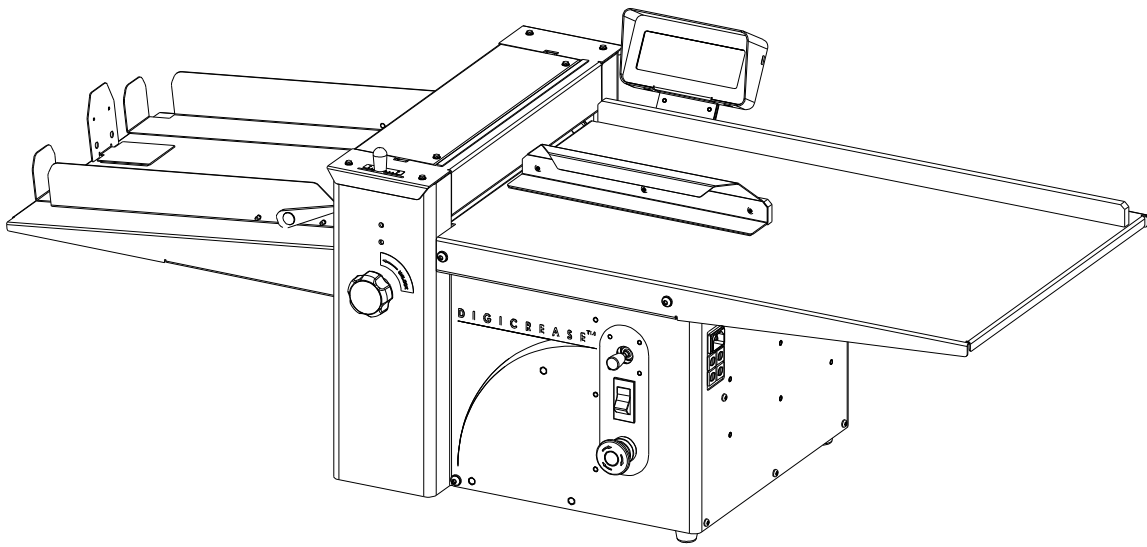

HAND FED DOCUMENT CREASING MACHINE

1

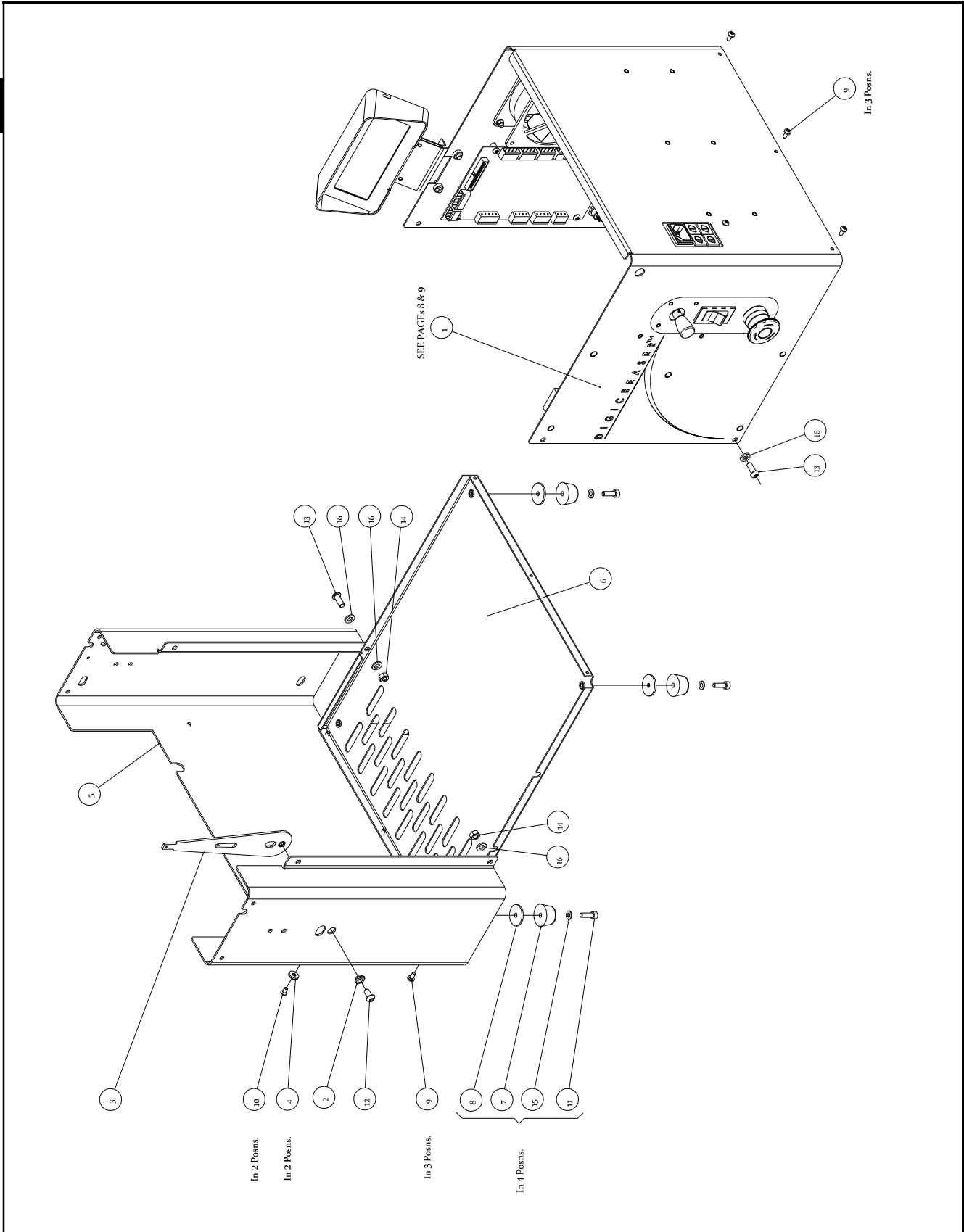

ITEM No.	PART No.	QTY.	Description
1	7-05-12	1	SERVICES - DigiCrease - Desktop.
2	71-010	1	Pivot Bush
3	71-013-02	1	TILT LEVER - MK2.
4	71-015	2	Pad
5	72-001-01	1	FRAME - Desktop.
6	72-003-01	1	PLINTH - Desktop.
7	601-154	4	FOOT
8	605-069	4	Mudguard Washer
9	401-02-040-008	6	Screw - Pan Pozi Taptite - M4 x 8 Lg.
10	402-02-040-008	2	Screw - Csk Hd. Taptite - M4 x 8 Lg.
11	403-01-050-016	4	SCREW - Socket Cap Head - M5 x 16 Lg.
12	405-01-060-012	1	SCREW - Socket Button Head - M8 x 16 Lg.
13	405-01-060-016	2	SCREW - Socket Button Head - M6 x 16 g.
14	461-01-060	2	NUT - Full - M6
15	481-050	4	WASHER - Plain - M5
16	481-060	4	WASHER - Plain - M6

1

1

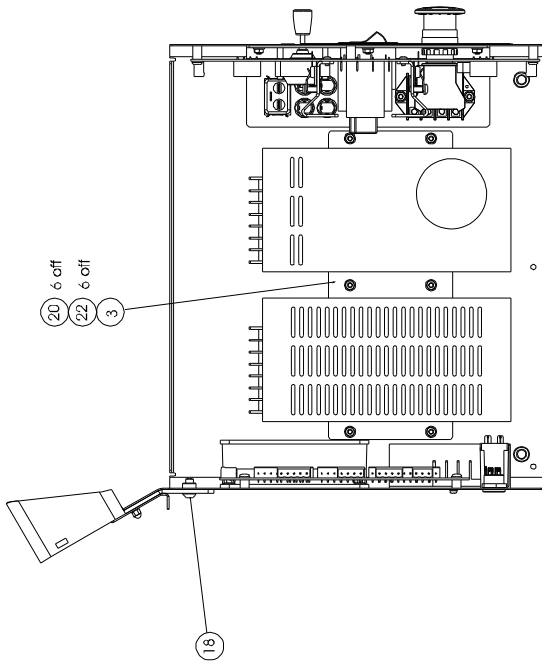

ITEM NO.	PART NUMBER	QTY.	Description
1	72-002-01	1	Control Cover - Desktop
2	72-016-01	1	LABEL - Digicreaser
3	72-023-01	1	MOUNTING PLATE - 48V & 24V P.S.U.
4	75-210-05	1	4 Line Display Unit - MK3
5	75-298-01	1	Control PCB MK3
6	75-255	1	DIN Socket Assy.
7	75-270-01	1	Control Panel Assembly
8	125-21-02	1	Stepper Drive PCB Assembly
9	613-053	1	119mm Fan
10	655-014	1	PSU - Switch Mode - 5V
11	655-015	1	PSU - Switch Mode - 24V
12	655-016	1	PSU - Switch Mode - 48V
13	689-005	1	Relay 10A - 230VAC - DPCO
14	401-02-030-008	2	Screw - Pan Pozz Tapfille - M3 x 8 Lg.
15	401-02-040-006	9	Screw - Pan Pozz Tapfille - M4 x 6 Lg.
16	401-02-040-008	1	Screw - Pan Pozz Tapfille - M4 x 8 Lg.
17	402-02-040-006	4	Screw - Csk Hd. Tapfille - M4 x 6 Lg.
18	405-01-060-012	2	Screw - Socket Button Head - M8 x 1.6 Lg.
19	461-01-030	2	NUT - Full - M3
20	461-01-040	15	NUT - Full - M4
21	481-030	4	WASHER - Plain - M3
22	481-040	14	WASHER - Plain - M4

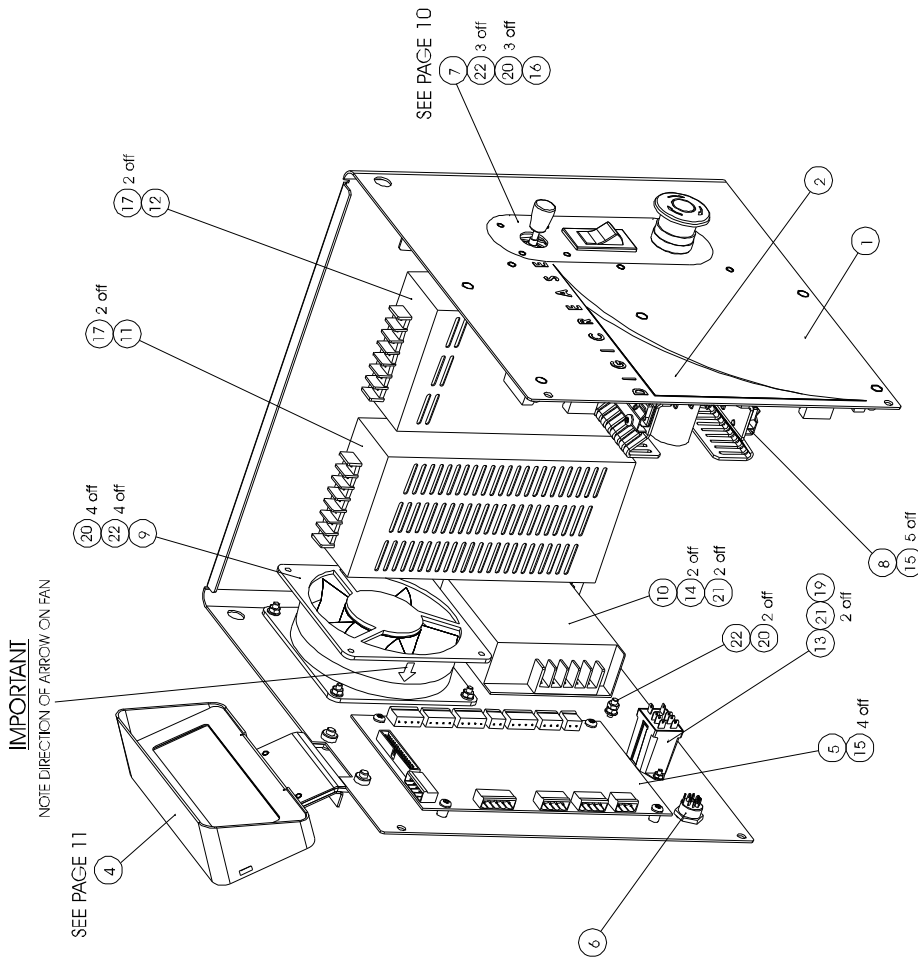

7-05-12 (MK1) (Serial Nos. 770001 to 770180)

(Services - Digicreaser - Desktop)

(THIS BUILD CANNOT BE USED IN THE USA)

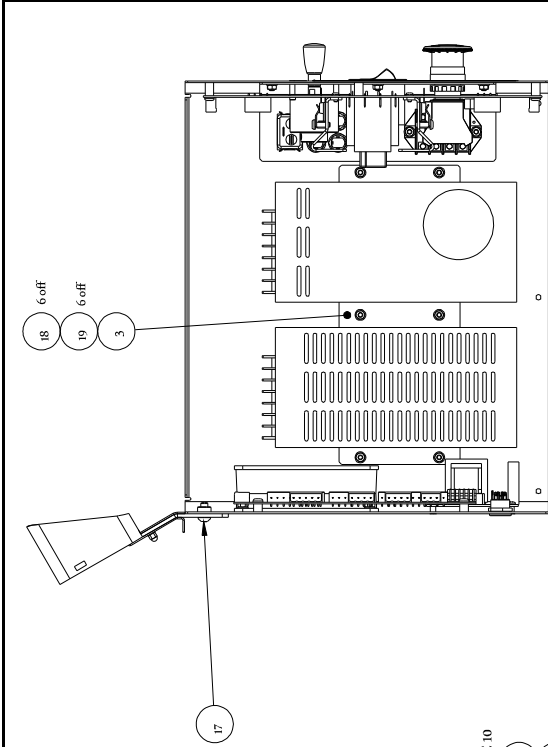

ITEM NO.	PART NUMBER	QTY.	Description
1	72-802-01	1	Control Cover - Desktop
2	72-816-01	1	LABEL - Digicreaser
3	72-802-01	1	MOUNTING PLATE -48V & 24V P.S.U.
4	75-210-05	1	4 Line Display Unit - MKS
5	75-247-01	1	Control PCB Digicreaser
6	75-225	1	DIN Socket Assy.
7	75-849-01	1	Control Panel Assembly
8	125-211-02	1	Stepper Drive PCB Assembly
9	615-053	1	100mm Fan
10	655-011	1	PSU - Switch Mode - 5V / 24V
11	655-015	1	PSU - Switch Mode - 24V
12	655-016	1	PSU - Switch Mode -48V
13	401-02-030-005	4	Screw - Pan Pozz Taprite - M3 x 6 Lg.
14	401-02-040-005	9	Screw - Pan Pozz Taprite - M4 x 6 Lg.
15	401-02-040-008	1	Screw - Pan Pozz Taprite - M4 x 8 Lg.
16	402-02-040-006	4	Screw - C&H Taprite - M4 x 6 Lg.
17	405-01-060-012	2	Screw - Socket Button Head - M8 x 10 Lg.
18	461-01-040	15	NUT - Full - M4
19	481-040	14	WASHER - Plain - M4

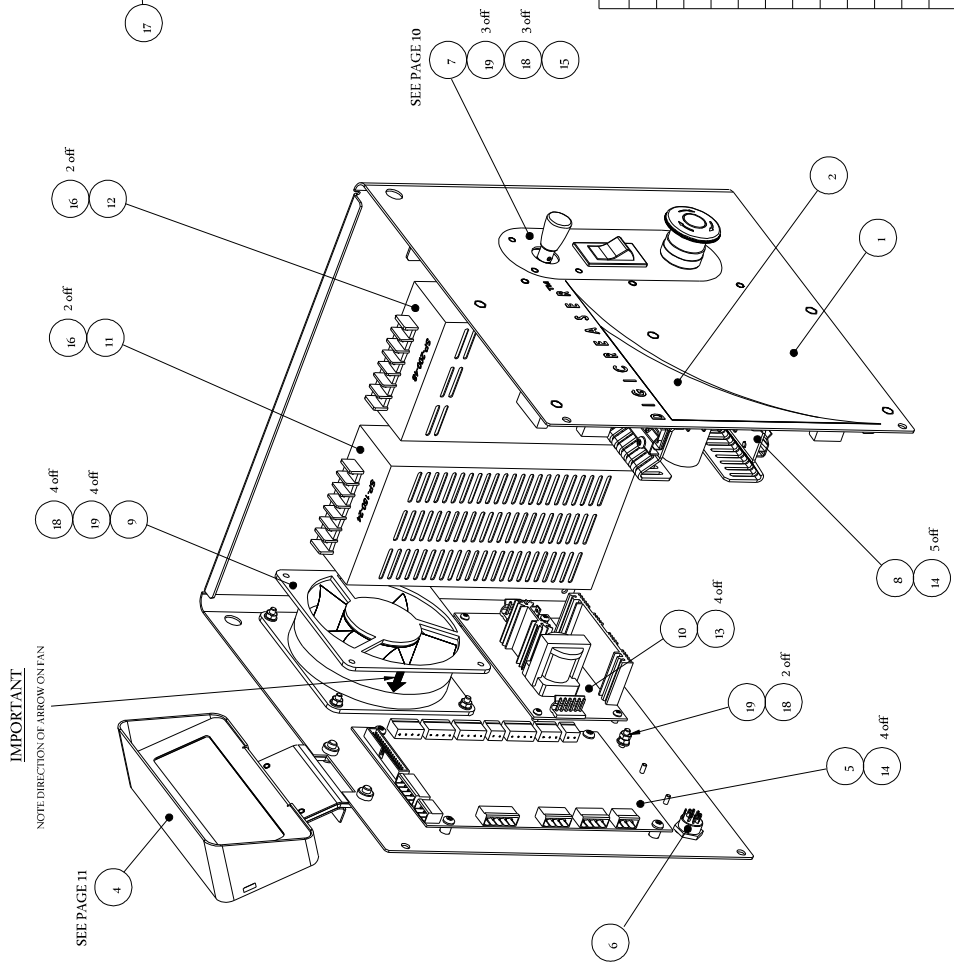

7-05-12 (MK2) (Serial Nos. 770264KFAD Onwards)
 (Services - Digicreaser - Desktop)

(THIS BUILD IS SUITABLE FOR USE IN ALL COUNTRIES)

1

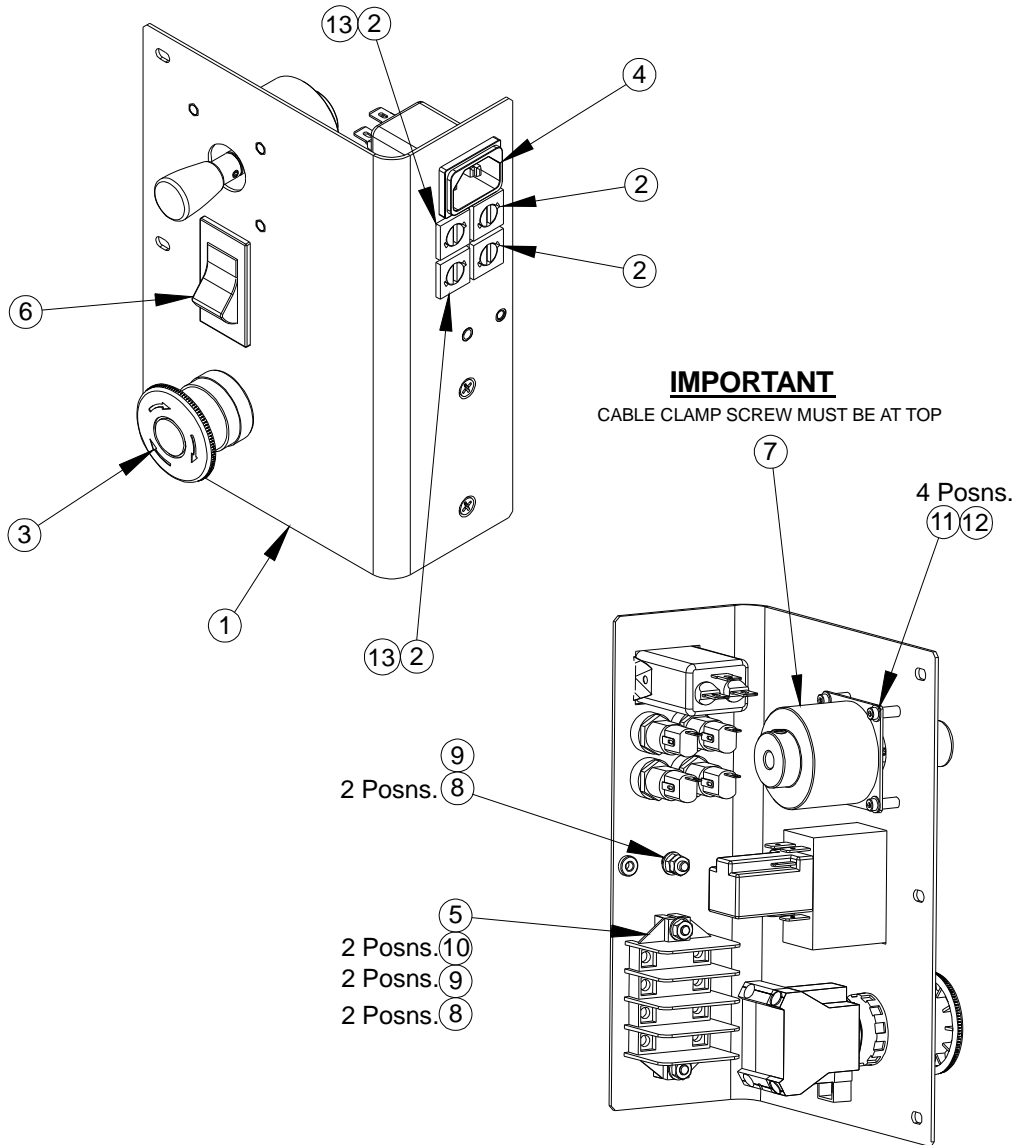

ITEM NO.	PART NUMBER	QTY.	Description
1	72-008-01	1	Control Panel
2	613-352	4	FUSE HOLDER - Ø5 x 20
3	613-365	1	EMERGENCY STOP SWITCH - Double Pole
4	651-047	1	IEC PLUG FILTER - CEE22
5	651-109	1	Tab Terminal Block - 4 way
6	652-011	1	SWITCH - System
7	144-04-04	1	JOYSTICK - Multi-Function - Digicreaser
8	461-01-040	4	NUT - Full - M4
9	481-040	4	WASHER - Plain - M4
10	402-02-040-016	2	Screw - Csk Hd. Taptite - M4 x 16 Lg.
11	403-01-025-008	4	Screw - Socket Cap Hd. - M2.5 x 8 Lg.
12	481-025	4	WASHER - Plain - M2.5
13	681-015	2	FUSE - 4.0A - 20mm x 5mm - ANTI-SURGE

75-349-01

(Control Panel Assembly)

ITEM NO.	PART NUMBER	QTY.	Description
1	75-211-03	1	Display Post - 4 Line
2	75-214-02	1	Display Hood - 4 Line
3	75-215-05	1	Display Hood Bezel - 4 Line
4	75-216-03	1	Display Unif Cable Cover
5	75-183	1	LCD Display Module (4 x 20) & Lead Assy
6	601-130	4	Washer - Nylon - M3
7	601-157	4	Screw - Ch Hd Slotted - Nylon - M2.5 x 6
8	402-02-030-006	4	Screw - Csk Hd. Tapfire - M3 x 6 Lg.
9	463-01-030	2	Domed Nut - M3
10	481-030	2	Washer - Plain - M3

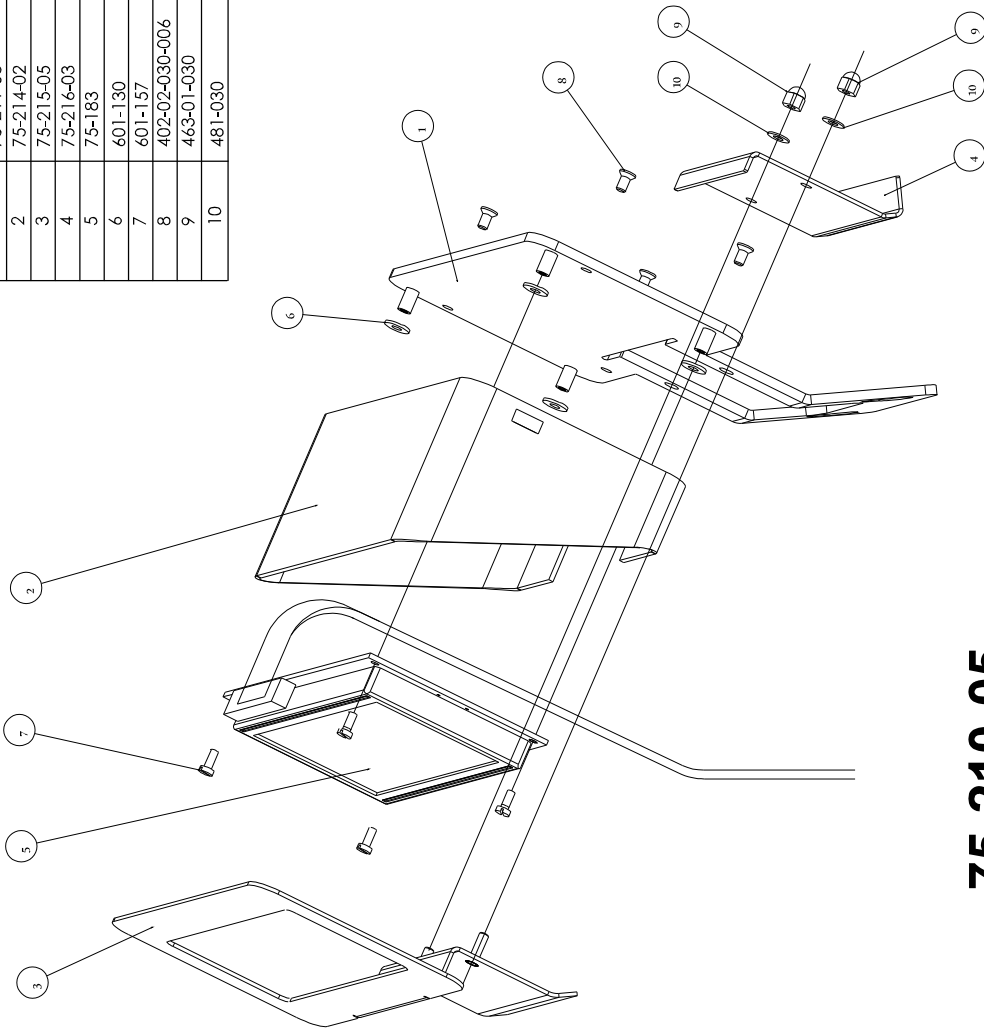

75-210-05
(4 Line Display Unit)

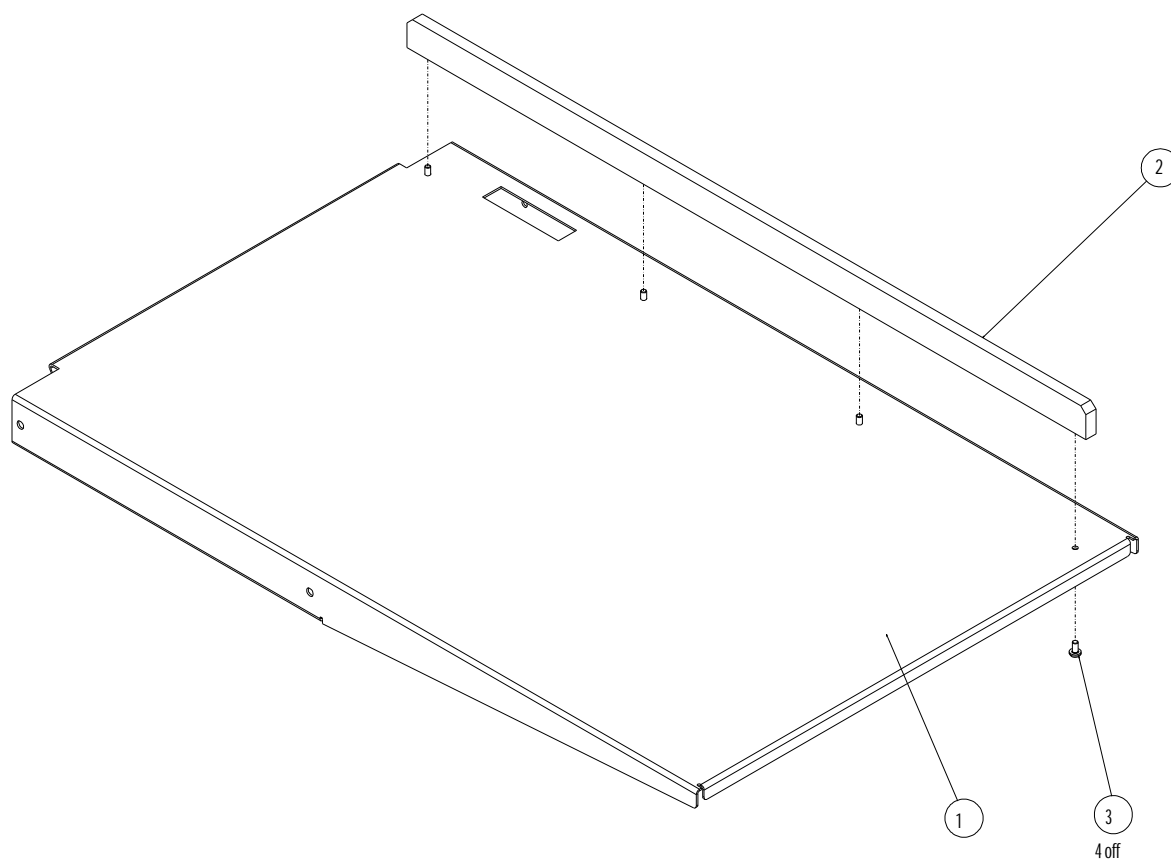
2

ITEM No.	PART No.	QTY.	Description
1	72-004-01	1	Feed Bed
2	72-005-02	1	SIDE LAY - Metric
3	401-02-040-008	4	Screw - Pan Pozzi Taplite - M4 x 8 Lg.

THIS
PAGE
BLANK

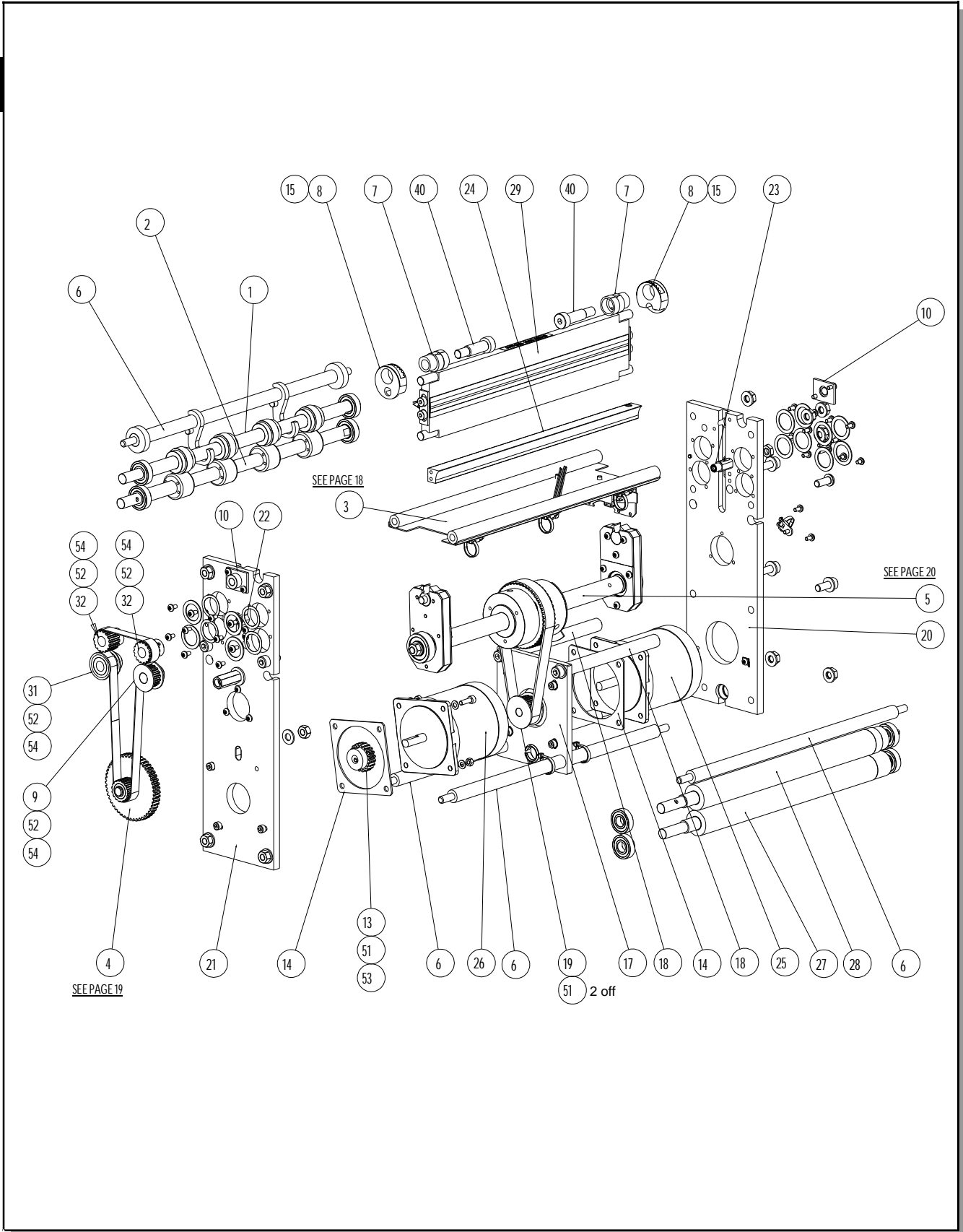

ITEM No.	PART No.	QTY.	Description
1	76-250-01	1	Upper Output Shaft Assy
2	76-251-01	1	Lower Output Shaft Assy
3	76-04-01	1	Splash Guard Assy
4	76-05-01	1	Idler Gear Assy
5	76-06-01	1	Crank Shaft Assy
6	76-003	4	TIE BAR - AutoCreaser.
7	76-011	2	BLADE ADJUSTMENT CAM.
8	76-012	2	ADJUSTMENT DISK - AutoCreaser
9	76-034-06	1	TIMING PULLEY - 16XL - Short Hub.
10	76-047	2	LOCK NUT - Blade Cam.
13	76-062-04	1	STEPPER PINION - 20T AutoCreaser 50
14	76-065	2	STEPPER SHIM
15	76-101	1	LABEL - Blade Adjustment.
17	76-121-01	1	MTG. PLATE - Stepper Motor.
18	76-122-01	2	TIE BAR - Female.
19	76-123-01	1	TIMING PULLEY - 20XL - Wide Flanged.
20	76-142-04	1	SIDE PLATE - Lay Side - Mk3.
21	76-142-05	1	SIDE PLATE - AC33 Op. Side Mk3
22	76-166	1	LEAD - Paper Jam Sensor.
23	76-167	1	LEAD - Dual Sensor Assy.
24	76-168	1	LEAD - Paper Guide Sensor
25	76-172	1	BLADE MOTOR & LEAD ASSY.
26	76-173	1	DRIVE MOTOR & LEAD ASSY.
27	76-175-01	1	INPUT ROLLER ASSY. - Lower
28	76-177-01	1	INPUT ROLLER ASSY. - Upper
29	76-213-01	1	BLADE SET - 320 Wide Std. Groove.
31	56-003-02	1	TIMING PULLEY Wide - 16XL - Flanged.
32	56-004-02	2	TIMING PULLEY - 16XL - Un-Flanged.
40	608-019	2	Shoulder Bolt - Ø12(M10) x 30 Lg.
51	407-01-050-006	3	Screw - Socket Set Knurled - M5 x 6 Lg.
52	409-01-040-004	4	Screw - Socket Set - Flat Point - M4 x 4 Lg.
53	409-01-050-005	1	Screw - Socket Set - Flat Point - M5 x 5 Lg.
54	411-01-040-006	4	Screw - Socket Set - Dog Point - M4 x 6 Lg.

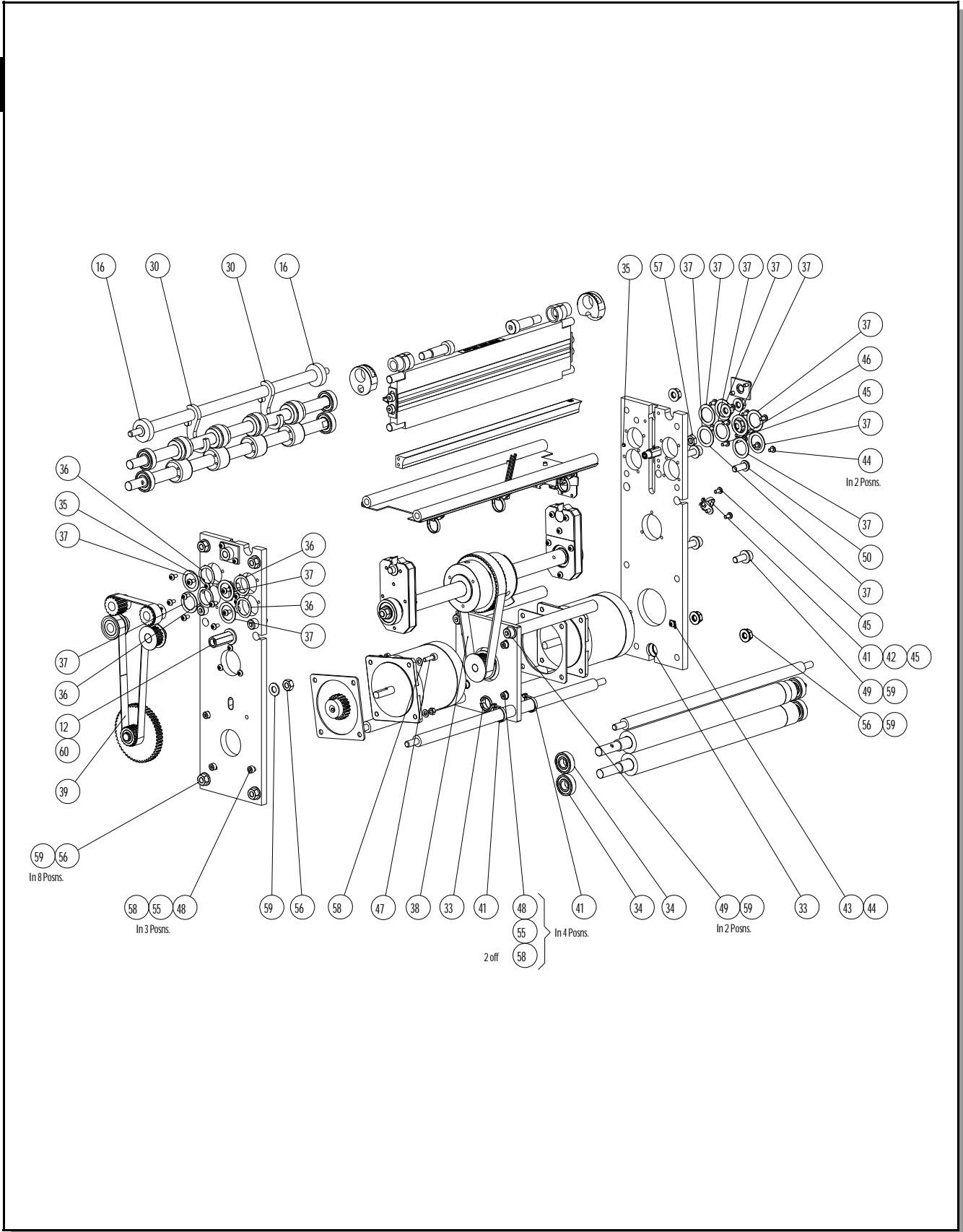

ITEM No.	PART No.	QTY.	Description
12	76-054-03	1	TILT PILLAR - AutoCreaser MK3
16	76-105	2	BUFFER - Exit Guard.
30	78-013	2	PERFORATOR STRIPPER ASSEMBLY.
33	601-124	2	HOLE BUSHING - Split - Ø19.
34	602-003	2	BEARING-Deep Groove Ball - 6001-ZZ
35	603-046	2	Spirol Pin - Ø4 x 12 Lg.
36	604-071	4	Waved Washer - Ø21 x Ø27.5 x 3.0
37	605-052	12	SUPPORT WASHER - Ø12
38	607-042	1	TIMING BELT - 160XL - 15.
39	607-048	1	TIMING BELT
41	613-027	3	TIE WRAP - Small.
42	613-339	1	CABLE TIE MOUNTING
43	651-031	1	TERMINAL STRIP - 45° - Single
44	401-02-040-006	3	Screw - Pan Pozi Taptite - M4 x 6 Lg.
45	401-02-040-008	28	Screw - Pan Pozi Taptite - M4 x 8 Lg.
46	401-02-040-016	4	Screw - Pan Pozi Taptite - M4 x 16 Lg.
47	403-01-050-016	1	Screw - Socket Cap Head - M5 x 16 Lg.
48	403-01-050-025	7	Screw - Socket Cap Head - M5 x 25 Lg.
49	403-01-080-020	7	Screw - Socket Cap Head - M8 x 20 Lg.
50	405-01-080-020	1	Screw - Button Hd. - M8 x 20 Lg.
55	461-01-050	7	Nut - Full - M5
56	461-01-080	9	Nut - Full - M8
57	462-01-080	1	Half Nut - M8
58	481-050	15	Washer - Plain - M5
59	481-080	16	Washer - Plain - M8
60	481-100	1	Washer - Plain - M10

3

3

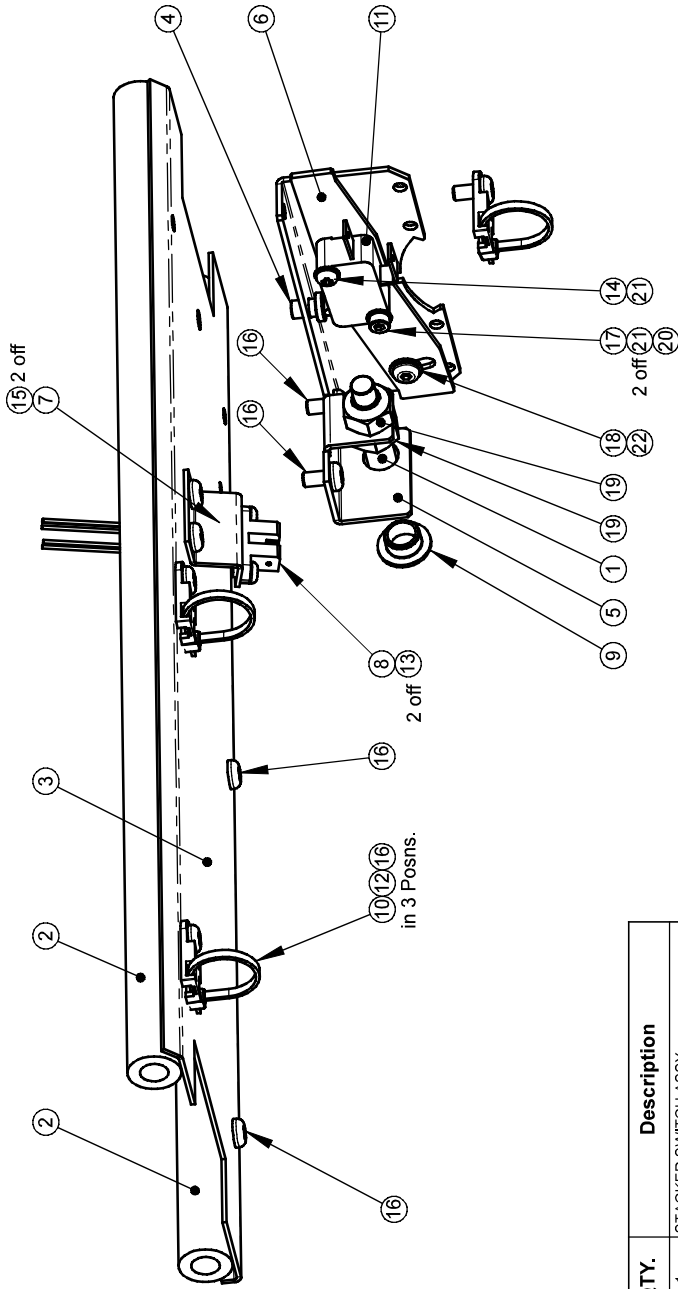

76-04-01

(Splash Guard Assembly)

ITEM No.	PART No.	QTY.	Description
1	75-040	1	STACKER SWITCH ASSY.
2	76-004	2	TIE BAR - AutoCreaser - Female.
3	76-052-05	1	SPLASH GUARD - AutoCreaser 33
4	76-086-03	1	SHOULDERED PAD - AutoCreaser- Mk2.
5	76-131	1	BRACKET - Combined Switch.
6	76-132	1	ADJUSTER PLATE - V3 MicroSwitch.
7	76-163-01	1	Slot Detector Bracket - Wide
8	76-169	1	SENSOR - Blade Position.
9	602-054	1	EP Bush - Ø8 x Ø10 x Ø15 x 5.5
10	613-027	3	TIE WRAP - Small.
11	613-191	1	MICROSWITCH
12	613-339	3	CABLE TIE MOUNTING
13	401-02-030-006	2	Screw - Pan Pozil Tapitite - M3 x 6 Lg.
14	401-02-030-016	1	Screw - Pan Pozil Tapitite - M3 x 16 Lg.
15	401-02-040-006	2	Screw - Pan Pozil Tapitite - M4 x 6 Lg.
16	401-02-040-008	7	Screw - Pan Pozil Tapitite - M4 x 8 Lg.
17	403-01-030-020	1	Screw - Socket Cap Head - M3 x 20 Lg.
18	405-01-040-006	1	Screw - Button Hd. - M4 x 6 Lg.
19	461-01-080	2	Nut - Full - M8
20	464-01-030	1	NUT - NYLOC - M3
21	481-030	3	Washer - Plain - M3
22	481-040	1	Washer - Plain - M4

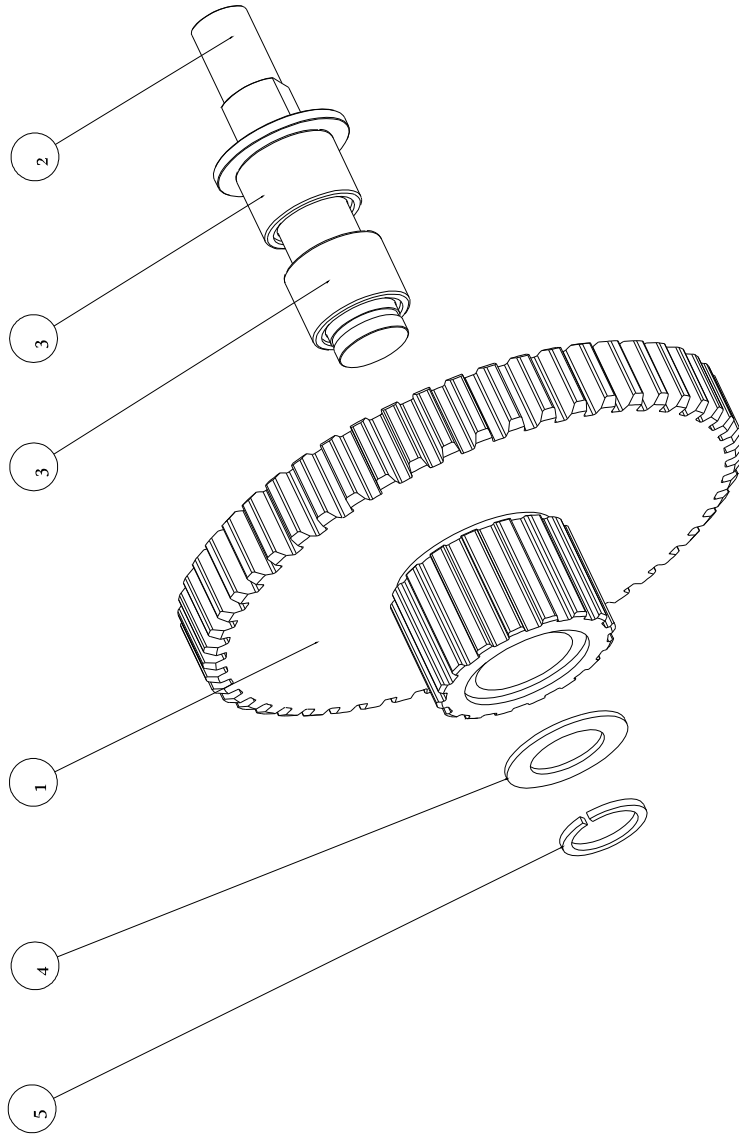

ITEM No.	PART No.	QTY.	Description
1	76-063-03	1	STEPPER IDLER - 50T Gear / 16XL Pulley.
2	76-064-02	1	IDLER STUD - AutoCreaser 50.
3	602-085	2	BEARING - Drawn Cup Needle Roller - HK1010
4	605-002	1	NYLON WASHER - Ø10.69 X17.45 X 0.79
5	615-043	1	RETAINING RING - External - Ø10

76-05-01

(Idler Gear Assembly)

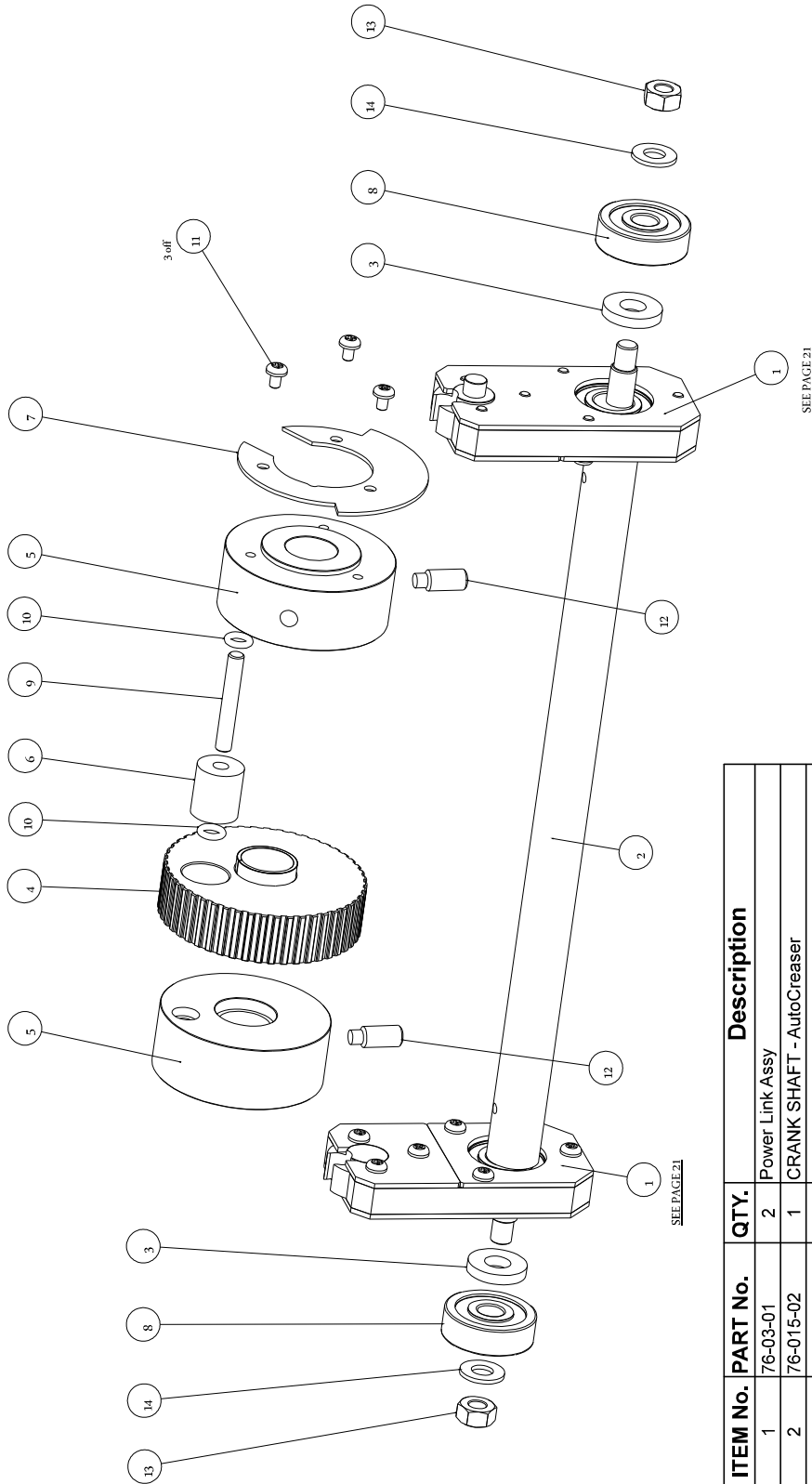

ITEM No.	PART No.	QTY.	Description
1	76-03-01	2	Power Link Assy
2	76-015-02	1	CRANK SHAFT - AutoCreaser
3	76-016	2	SPACER - Crank Shaft.
4	76-125	1	PULLEY ASSY. - Crankshaft.
5	76-126	2	TORSION HUB - AutoCreaser.
6	76-127	1	Torsion Bush
7	76-134-02	1	Slot Detector Disk - Small
8	602-082	2	BEARING-DEEP GROOVE BALL - 6300-ZZ
9	603-071	1	DOWEL - Ø6 x 40 Lg.
10	608-024	2	O'Ring.
11	401-02-040-006	3	Screw - Pan Pozi Tapitite - M4 x 6 Lg.
12	411-01-080-020	2	Screw - Socket Set - Dog Point - M8 x 20 Lg.
13	461-01-080	2	Nut - Full - M8
14	481-080	2	Washer - Plain - M8

76-06-01

(Crank Shaft Assembly)

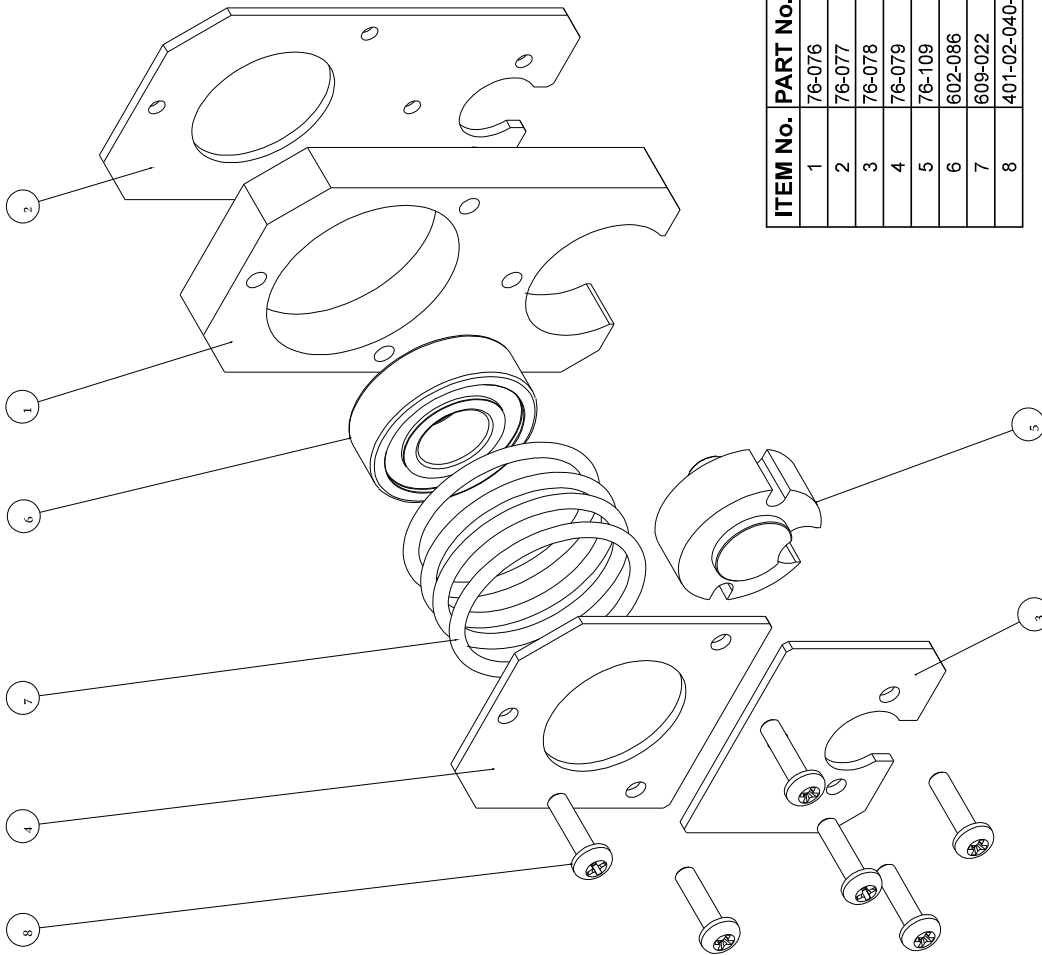

ITEM No.	PART No.	QTY.	Description
1	76-076	1	POWER LINK - Blade Crank Shaft.
2	76-077	1	LINK PLATE - Tapped.
3	76-078	1	SHOCK RING PLATE.
4	76-079	1	LINK - Bearing Plate.
5	76-109	1	BEARING - Power Link.
6	602-086	1	BEARING-Deep Groove Ball - 6202-ZZ
7	609-022	4	O Ring.
8	401-02-040-016	6	Screw - Pan Pozzi Tapitte - M4 x 16 Lg.

76-03-01

(Power Link Assembly)

4

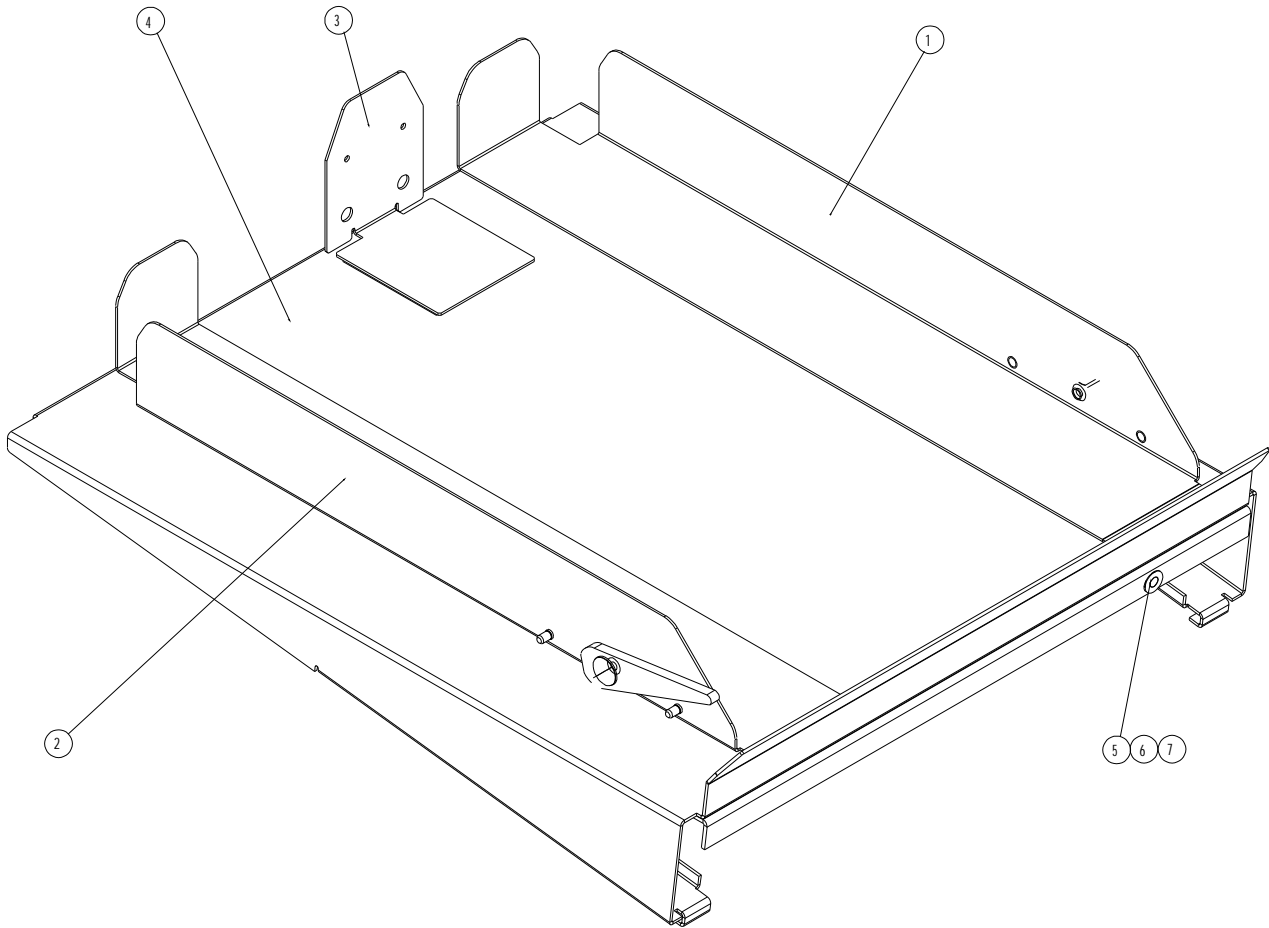

ITEM No.	PART No.	QTY.	Description
1	78-005	1	Stacker Guide Assy. L/H
2	78-006	1	Stacker Guide Assy. R/H
3	78-007	1	BACKSTOP Assy.
4	78-014	1	STACKER
5	88-040	1	Actuator Mtg Assy.
6	603-028	1	SPIROL SPACER - Ø8 x Ø10.55x 8 Lg
7	615-009	1	Starlock Washer

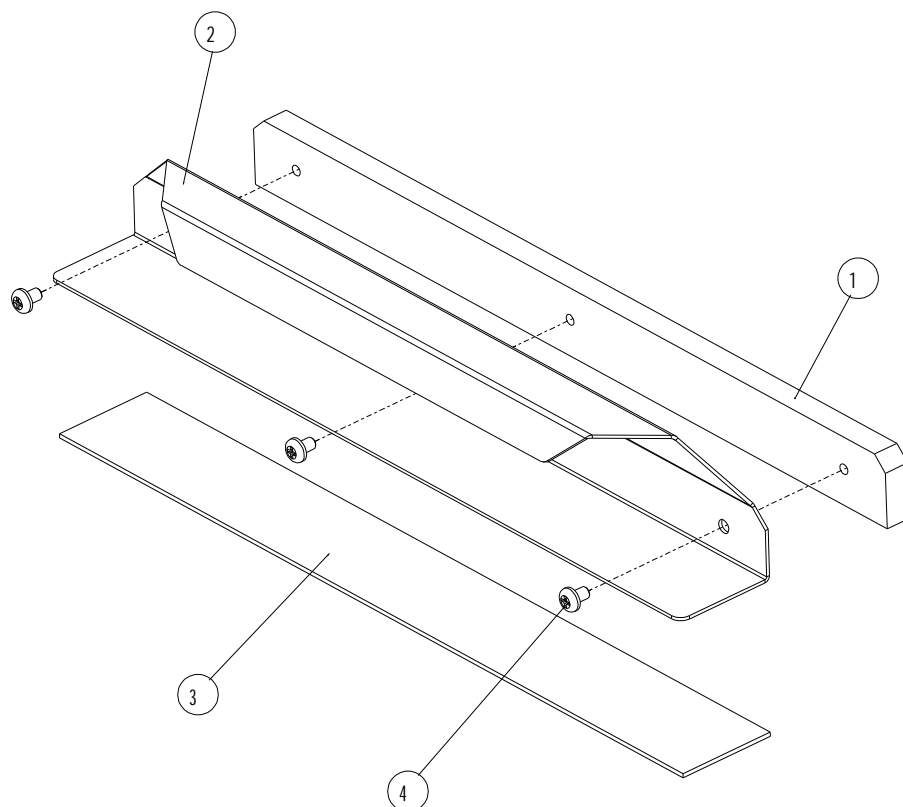

ITEM No.	PART No.	QTY.	Description
1	72-020-01	1	MOVING SIDE LAY
2	72-021-01	1	HANDLE - Moving Sidelay
3	78-009-03	1	MAGNETIC STRIP
4	401-02-040-006	3	Screw - Pan Pozi Taptite - M4 x 6 Lg

6

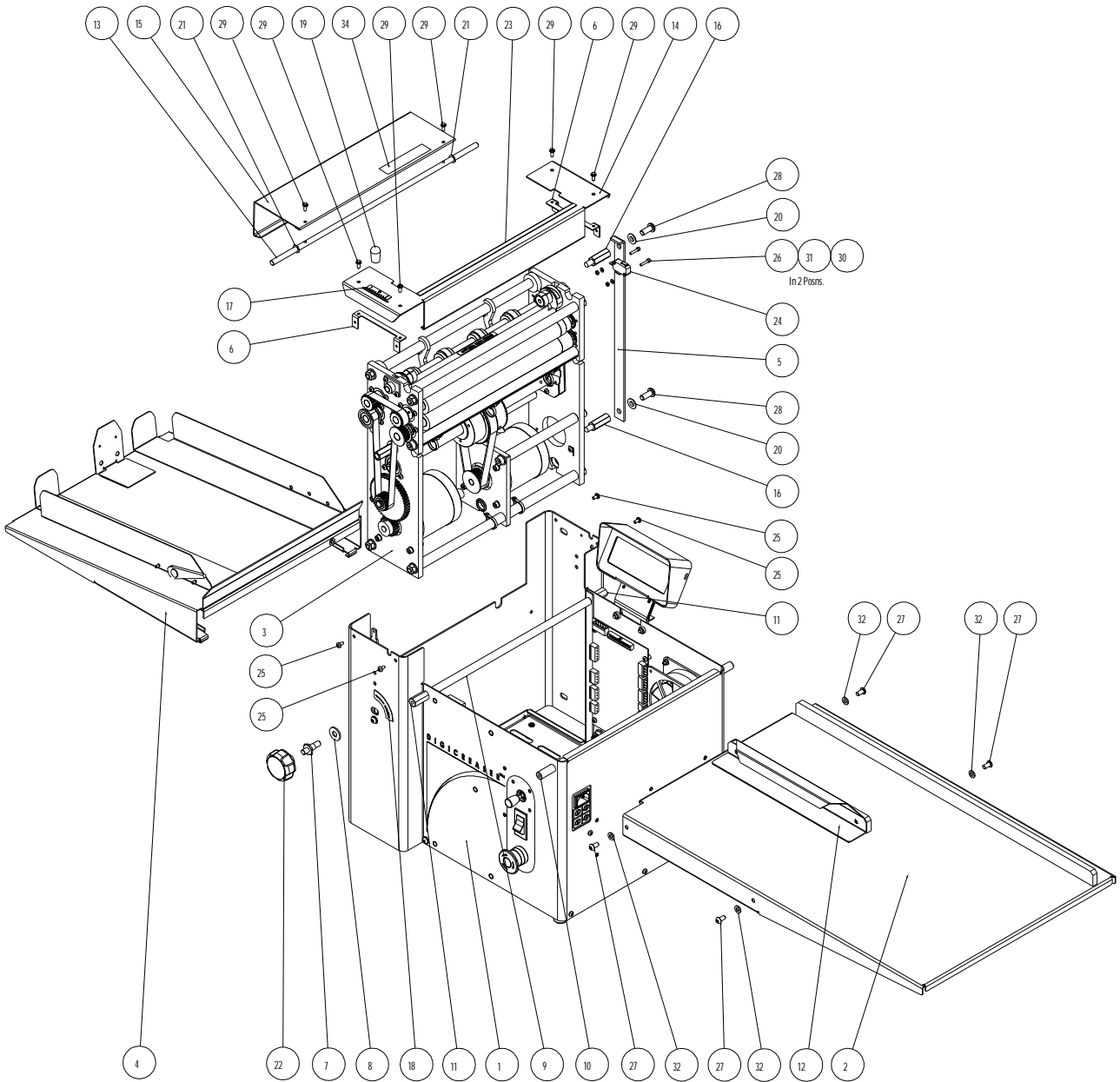

ITEM No.	PART No.	QTY.	Description
1	7-01-15	1	MAIN FRAME ASSEMBLY - Desktop.
2	7-03-12	1	LOADING TABLE ASSEMBLY.
3	7-06-12	1	CREASING UNIT ASSY. - Autocreaser 33.
4	7-08-01	1	STACKER ASSEMBLY.
5	71-011	1	HINGE PLATE - AutoCreaser.
6	71-012-02	2	COVER BRACKET - Mk2.
7	71-020	1	LOCKING STUD - Clamp
8	71-025	1	Tilt Washer
9	72-006-01	1	TIE BAR - Frame - DigiCrease.
10	72-006-02	1	Tie Bar - Feed Bed
11	72-007-01	2	Pillar - Feed Bed
12	75-022-01	1	MOVING SIDELAY ASSEMBLY.
13	76-049-05	1	Hinge Shaft - DigiCrease
14	76-050-06	1	Entry Guard - DigiCrease
15	76-051	1	EXIT GUARD - AutoCreaser.
16	76-053-03	2	HINGE PILLAR - DigiCrease.
17	96-053	1	Label - Roller Tilt
18	96-060	1	LABEL - Lock
19	601-111	1	Tapered Ferrule
20	605-055	2	WASHER - Self Aligning
21	605-056	2	THRUST WASHER - Ø12.7 x Ø8.00 x 0.81
22	606-035	1	LOBE KNOB - Female - M8
23	609-009	1	EDGING STRIP.
24	613-351	1	MICROSWITCH
25	401-02-040-008	4	Screw - Pan Pozi Taptite - M4 x 8 Lg.
26	403-01-030-016	2	Screw - Socket Cap Head - M3 x 16 Lg.
27	405-01-060-012	4	SCREW - Socket Button Head - M8 x 16 Lg.
28	405-01-080-020	2	Screw - Button Hd. - M8 x 20 Lg.
29	406-01-040-006	6	SCREW - Tamperproof - M4 x 6 Lg
30	464-01-030	2	NYLOC Nut - M3
31	481-030	2	Washer - Plain - M3
32	481-060	4	WASHER - Plain - M6
34	123-059	1	LABEL - Safety Warnings

7

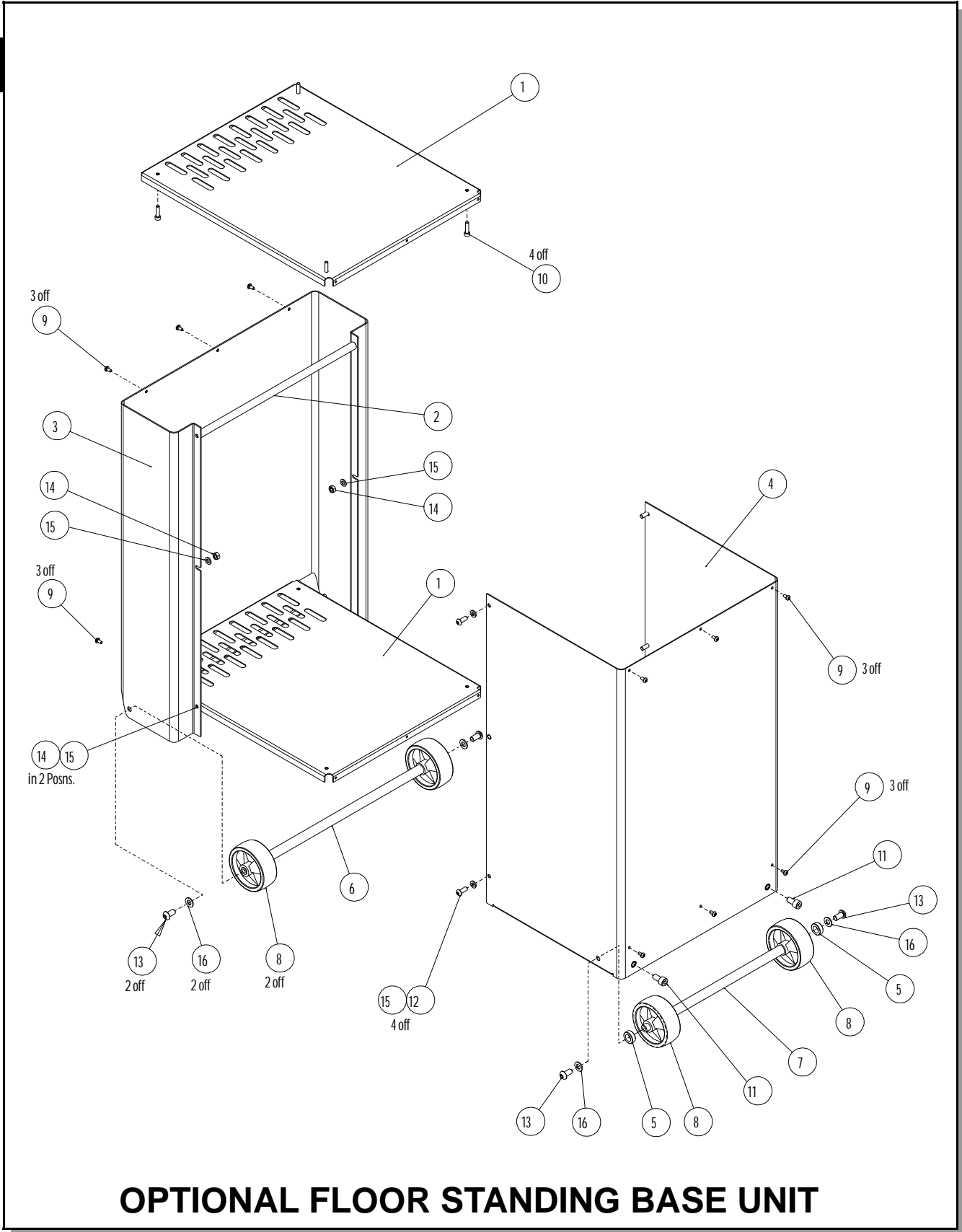

OPTIONAL FLOOR STANDING BASE UNIT

ITEM No.	PART No.	QTY.	Description
1	72-003-02	2	PLINTH - Base
2	72-006-01	1	TIE BAR - Frame - DigiCrease.
3	72-011-01	1	Base Frame
4	72-012-01	1	BASE COVER
5	72-014-01	2	Short Wheel Spacer
6	72-015-01	1	Wheel Shaft - Rear
7	72-015-02	1	Wheel Shaft - Front
8	617-011	4	Wheel
9	401-02-040-008	12	Screw - Pan Pozi Taptite - M4 x 8 Lg.
10	403-01-050-020	4	SCREW - Socket Cap Head - M5 x 20 Lg.
11	403-01-080-016	2	SCREW - Socket Cap Head - M8 x 16 Lg.
12	405-01-060-016	4	SCREW - Socket Button Head - M6 x 16 g.
13	405-01-080-016	4	SCREW - Socket Button Head - M8 x 16 g.
14	461-01-060	4	NUT - Full - M6
15	481-060	8	WASHER - Plain - M6
16	481-080	4	WASHER - Plain - M8

7

