

*Morgana*

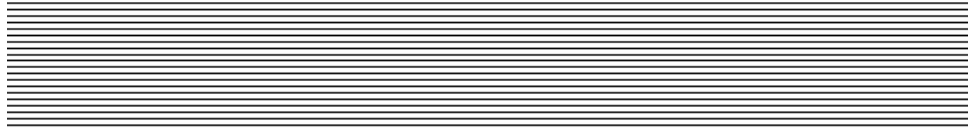

**FRN 5**

**ROTARY NUMBERING  
MACHINE**

**OPERATORS GUIDE**

*Morgana Systems Limited    Snowdon Drive    WinterHill  
Milton Keynes    Buckinghamshire    MK6 1AP    United  
Kingdom    Telephone: ( 01908 ) 608888    Facsimile:*

**ISSUE 2    APRIL 1994**

*Morgana* **FRN**  
**ROTARY NUMBERING MACHINE**

---

<b>Section .. 1</b>	<b>.....Installation</b>	<b>.....Page 4</b>
1.1	Guards	4
1.2	Feed Bed	4
1.3	Stacker	5
<b>Section .. 2</b>	<b>.....Controls</b>	<b>.....Page 6</b>
2.1	Switches	6
2.2	Knobs	7
<b>Section .. 3</b>	<b>.....Setting</b>	<b>.....Page 8</b>
3.1	Feed Bed	8
3.2	Numbering	10
3.3	Numbering Digits	10
3.4	Hold Down Wheels	11
3.5	Advance Cam	12
3.6	Stacker	13
<b>Section . 4</b>	<b>.....Inking</b>	<b>.....Page 14</b>
4.1	Setting	14
4.2	Fitting Ink Roller to Pod	14
4.3	Fitting Ink Pod to Machine	15
4.4	Re-Inkable Ink Roller	16
4.5	Secondary Inking Position	18
<b>Section . 5</b>	<b>.....Make Ready</b>	<b>.....Page 20</b>
<b>Section .. 6</b>	<b>.....Specifications</b>	<b>.....Page 21</b>
6.1	Technical Specifications	21
6.2	Spacing of Numbers	22
6.3	Sheet Sizes & Perforation Spacing	23
<b>Section . 7</b>	<b>.....Perforating.....</b>	<b>.....Page 24</b>
<b>Section .. 8</b>	<b>.....Slitting</b>	<b>.....Page 26</b>
<b>Section .. 9</b>	<b>.....Scoring</b>	<b>.....Page 27</b>
<b>Section .. 10</b>	<b>.....Maintenance</b>	<b>.....Page 28</b>
10.1	Paper Jams	28
10.2	Sensor	29
10.3	Transfer Roller	29
10.4	Numbering Head	30
10.5	Dismantling Numbering Head	31
10.6	Re-Assembling Numbering Head	33
<b>Section .. 11</b>	<b>.....Troubleshooting</b>	<b>.....Page 34</b>

When the machine is not in use, the Feed Bed may be withdrawn and hung on the stowage hooks.

### 1.3 ..... Stacker

The Stacker is fitted, by locating the support shafts each side into the catch plates. Raising the end of the Stacker will allow it to fit. It may then be lowered into position.

The height adjustment screws on each side may be positioned to obtain the optimum height. It is recommended that only one screw at a time (using a 5mm Allen key), is released when adjusting the Stacker height.

When not in use, the Stacker may be hung on the stowage hooks on the base of the machine.

With the Stacker removed, the exit guard will drop fully for the best access to the output shafts.

**NOTE.....** The machine will not run with the Guards open or with the Feed Bed removed.

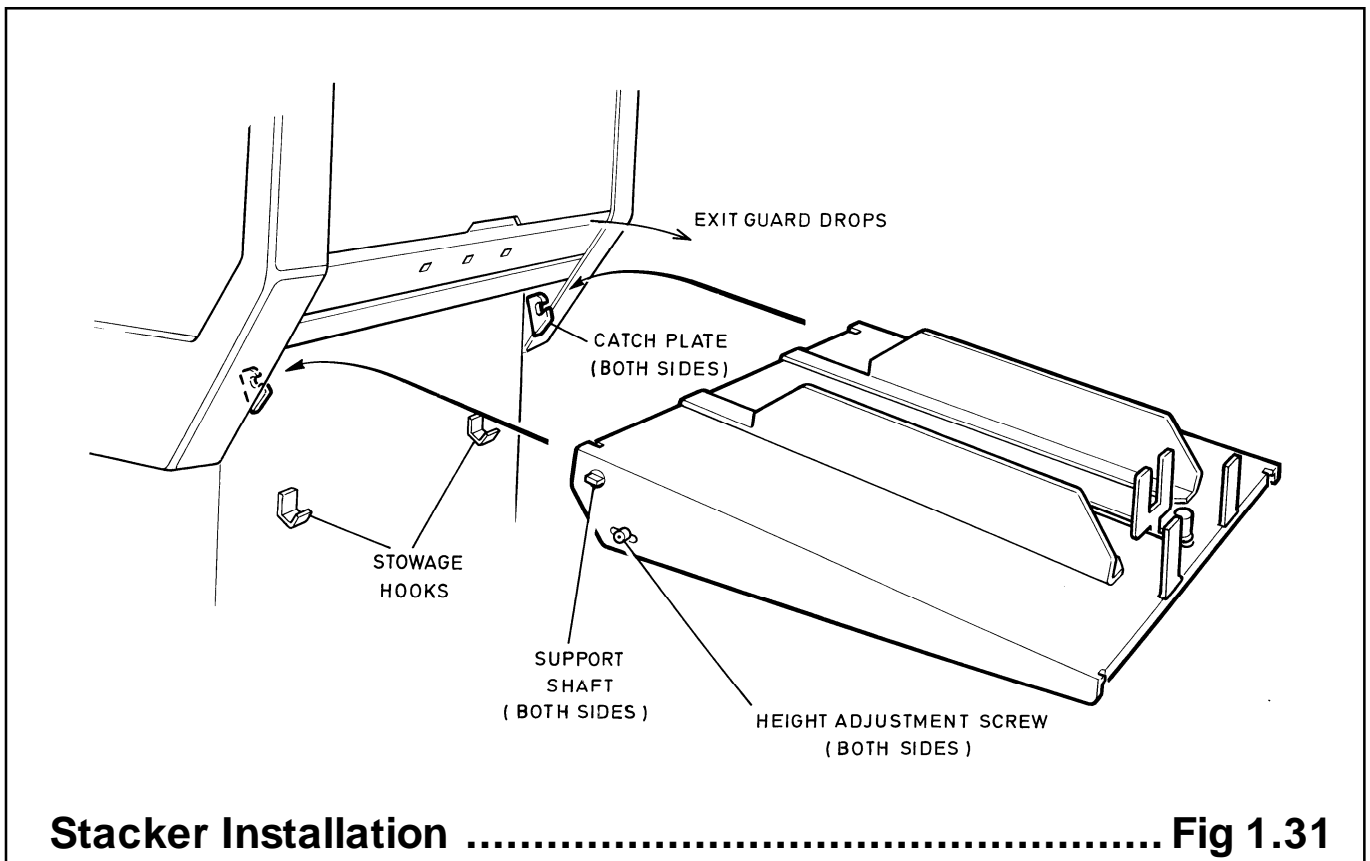

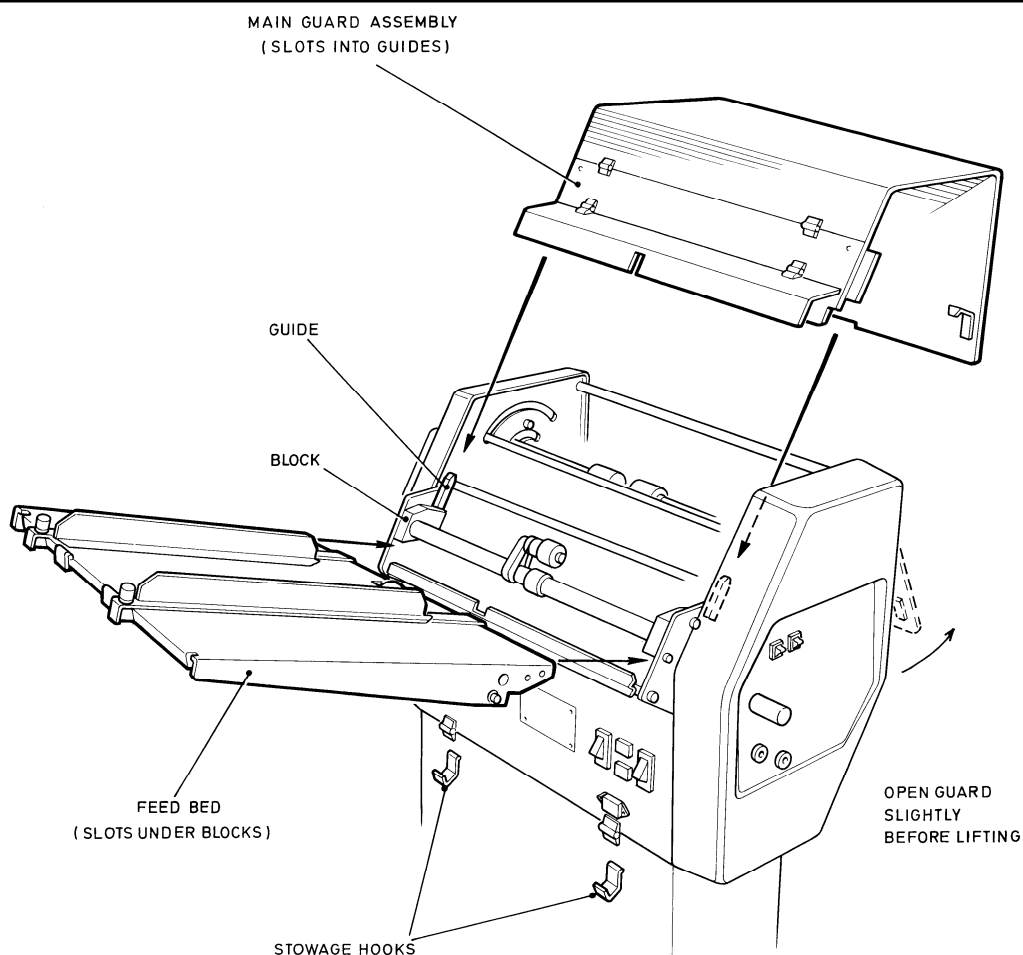

**Feed Bed & Guards ..... Fig 1.11**

## 1.1 .....Guard

The Main Guard is normally opened at the stacker end, and is pivoted all the way over, until it rests on the feeder. The complete guard may be removed from the machine by lifting it off it's guides, as shown in Fig. 1.11

## 1.2 .....Feed Bed

The Feed Bed slots into position below the feed shaft housing blocks. When correctly fitted, the Bed will rest flat against the bottom edge of these blocks. The back of the Bed has to be raised slightly, so that it can be fitted, and removed, but do not raise it too high. Ensure that the Bed is fully forward to the stops on both sides.

The Feed Bed will not fit, if the friction nip wheel ( Fig. 3.11 page 8 ) has been raised or lowered too far. Adjust the wheel accordingly.

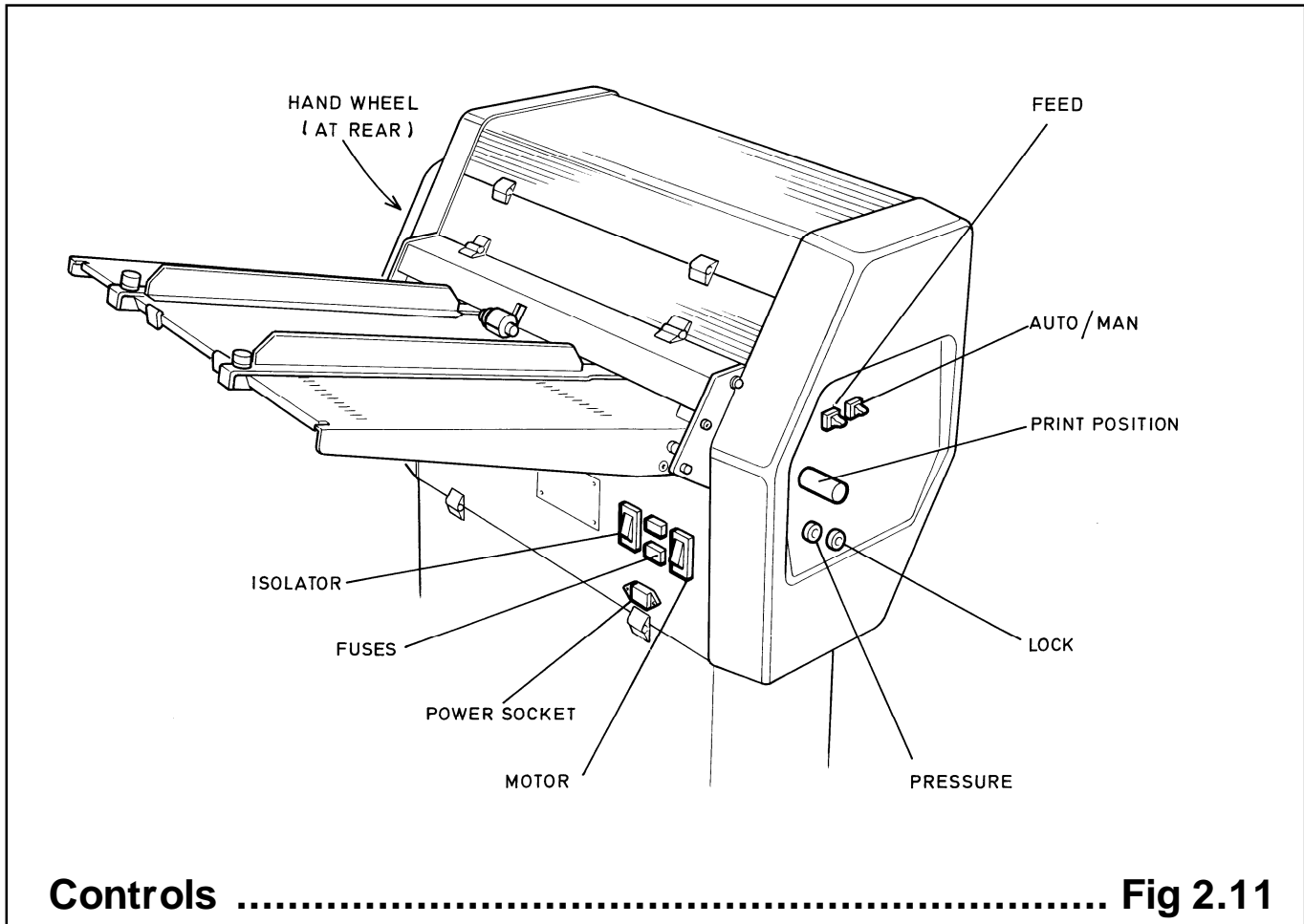

## 2.1 ..... Switches

- Isolator** This is the main switch to isolate the machine from the power supply.
- Motor** Switches the drive on or off. If a guard is open, or the feed bed removed, this switch will not latch. If the guard is opened while the machine is running, this switch will trip and stop the machine.
- Feed** This switch will engage the paper feed drive.
- Auto/Man** This switch will release the main print shaft, to allow setting of the numbering heads.

### WARNING

**NEVER OPERATE THE AUTO / MAN SWITCH WHILST THE MACHINE IS RUNNING.**

## 2.2 ..... Control Knobs

**Handwheel.** The handwheel is located at the rear of the machine, and is used when setting-up.

**Print position** The fine adjust control which gives +7mm or -7mm (  $+1/4''$  or  $-1/4''$  ) of movement to the print position.

The three rings indicate the general position of the control and clockwise rotation will move the number down the sheet.

One full revolution moves the print position 1mm ( $3/64''$ ) The control may be adjusted whilst the machine is running.

**Platen Pressure & Lock** The printing pressure may be adjusted as follows:-

Fit a 4mm Allen key into the lock and a 5mm Allen key into the pressure control.

Loosen the lock and turn the pressure control, either towards minimum or maximum, as required.

Hold the pressure control and tighten the lock, using LIGHT pressure.

The pressure control has a small mark to indicate it's position.

**NOTE** ..... It is not necessary to overtighten the lock as this can damage the mechanism.

### WARNING

**ALWAYS OPERATE THE MACHINE AT THE LOWEST PLATEN PRESSURE NECESSARY TO MAKE A SATISFACTORY PRINT. DAMAGE TO THE MACHINE WILL OCCUR IF EXCESSIVE PRINTING PRESSURES ARE USED.**

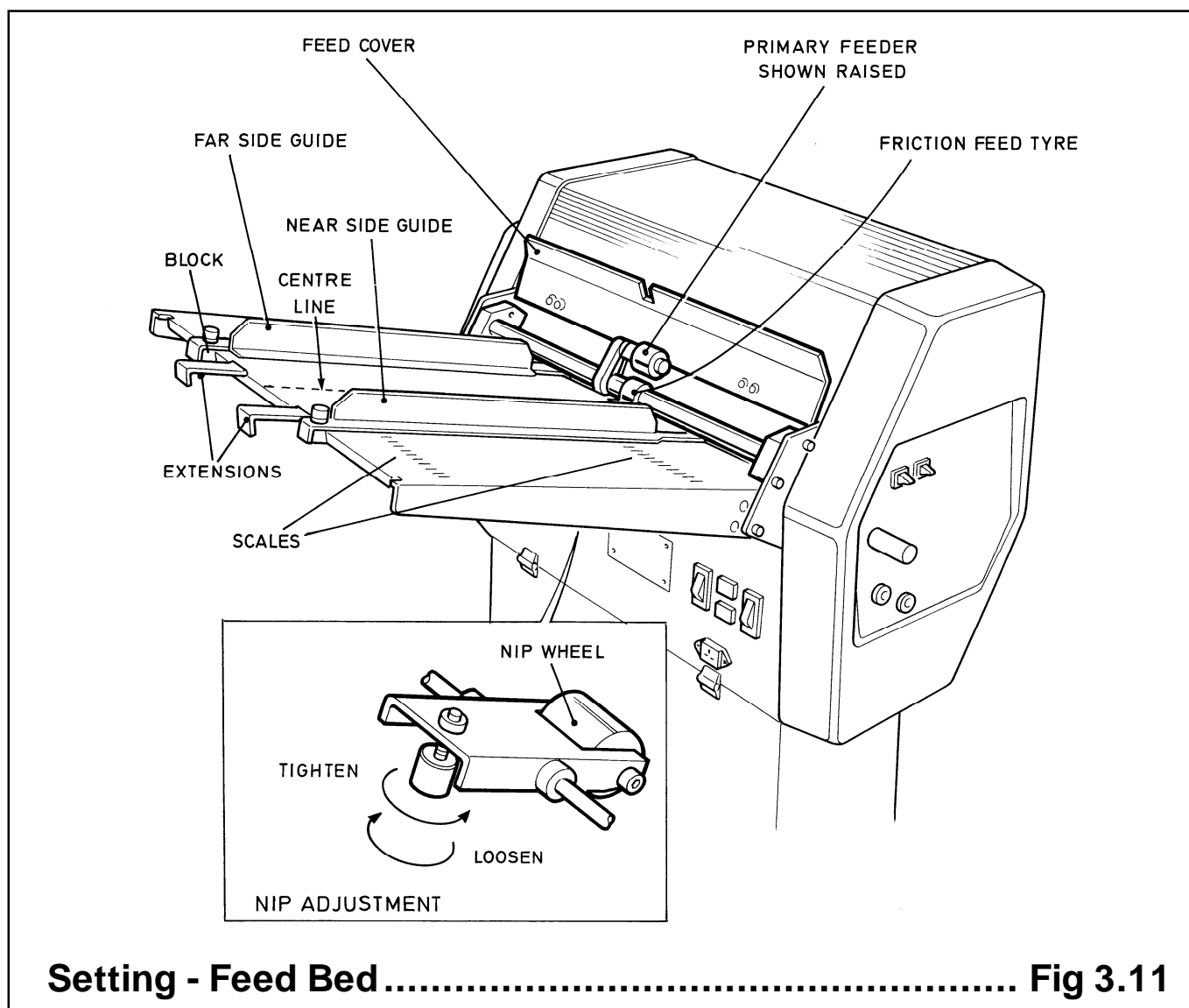

### 3.1 ..... Feed Bed

The Feed Bed is set as follows:-

- Raise the feed cover.
- Raise the primary sheet feeder.
- Loosen both side guide locks and open up the side guides, to allow one sheet of your job to be placed on the Feed Bed.
- Paper is normally fed centrally on the machine, and setting the near side-guide to the scales, will facilitate this. Set the inside edge of the side guide to the scale. (See note 3 for feeding multi-part sets with glued edge to the side).

- For odd or unknown sizes, fold the workpiece in half, along its length, place on the centre line, and move the near side-guide up to the edge of the paper.
- Having set the near side-guide, set the far side-guide to the paper. Accurate positioning of these guides is essential for reliable and straight feeding.
- If set too tight, poor feeding will result. If set too loose, inconsistent perforating and scoring will result, and to a lesser extent, inconsistent numbering too.
- With both guides set, use a single piece of your work and pass it below the friction feed tyre.
- If the work will not fit below the friction feed tyre, loosen the nip wheel by turning the adjustment screw.
- Now tighten the nip adjustment until a very slight drag is felt on the paper or set. The feed bed is now ready for loading with paper.
- The paper must be spread out (shingled), so that the top sheet approaches the friction tyre first.
- Now place the primary feeder on to the work and lower the feed cover.

**Note 1.....** The scales are for guidance only, and the side guides may have to be adjusted to obtain a straight perforation.

**Note 2.....** If double or multiple sheet feeding occurs, tighten the nip adjustment.

**Note 3.....** For sets to be fed open edge leading, place the glued edge nearer to the feed wheel, instead of central. Offset by approximately 1/3 the width of the sheet.

## 3.2 .....Numbering

Fit a Numbering Head to a collar, using the scale on the collar to obtain the correct position. The scale relates to the distance from the top of the sheet, to the top of the number. Line up the back edge of the Numbering Head with the scale. (To make the scale position accessible, operate the Auto/Man switch and turn the machine using the handwheel at the rear of the machine See Fig 2.11)

Position the Numbering Head sideways, by releasing the collar locking screw. This locking screw is only accessible by operating the auto/man switch, (see 2.1) and rotating the machine by hand.

**NOTE .....** Every time the collars are moved, the advance cam will need moving and the hold-down wheels checked , by rotating the machine by hand. **NEVER** operate the machine under power until the auto/man switch has been released, and the Numbering Head has been turned one complete revolution by hand, to ensure that the hold-down wheels and advance cams are positioned correctly.

## 3.3 .....Setting Numbering Digits

Set the Numbering Head digit wheels using the pointed stylus, supplied with your Numbering Head. The wheels can only be turned in the direction shown in Fig. 3.21

To avoid having to reset the digit wheels after make-ready, set them to a number somewhat lower than, (forward heads) or higher than, (backward heads) your jobs required starting number.

Standard heads have seven digits. If less than seven digits are to be printed, up to six zero's may be depressed so that they do not print. ( This feature may not apply to all Numbering Heads )

To depress the digits, turn the digit wheel until the zero is at the top of the head. Turn the wheel further while pressing the zero down into the head. The zero will drop down and remain down.

To release the zero, turn the wheel further in the normal direction.

### 3.4 ..... Hold-Down Wheels

Set the Hold-Down Wheels ( which are simply pushed into position ) so that they run on the work but will not be in the way of the Numbering Heads.

It is important, particularly when Perforating or Slitting, that the Hold Down Wheels are positioned equally about the centre of the sheet. If this is not possible due to the position of the Numbering Heads, then set one Hold Down Wheel to run on the centre of the sheet.

**NOTE.....** If the Hold Down Wheels are not correctly positioned sheets may become misaligned causing inaccurate Perforating and possibly registration errors.

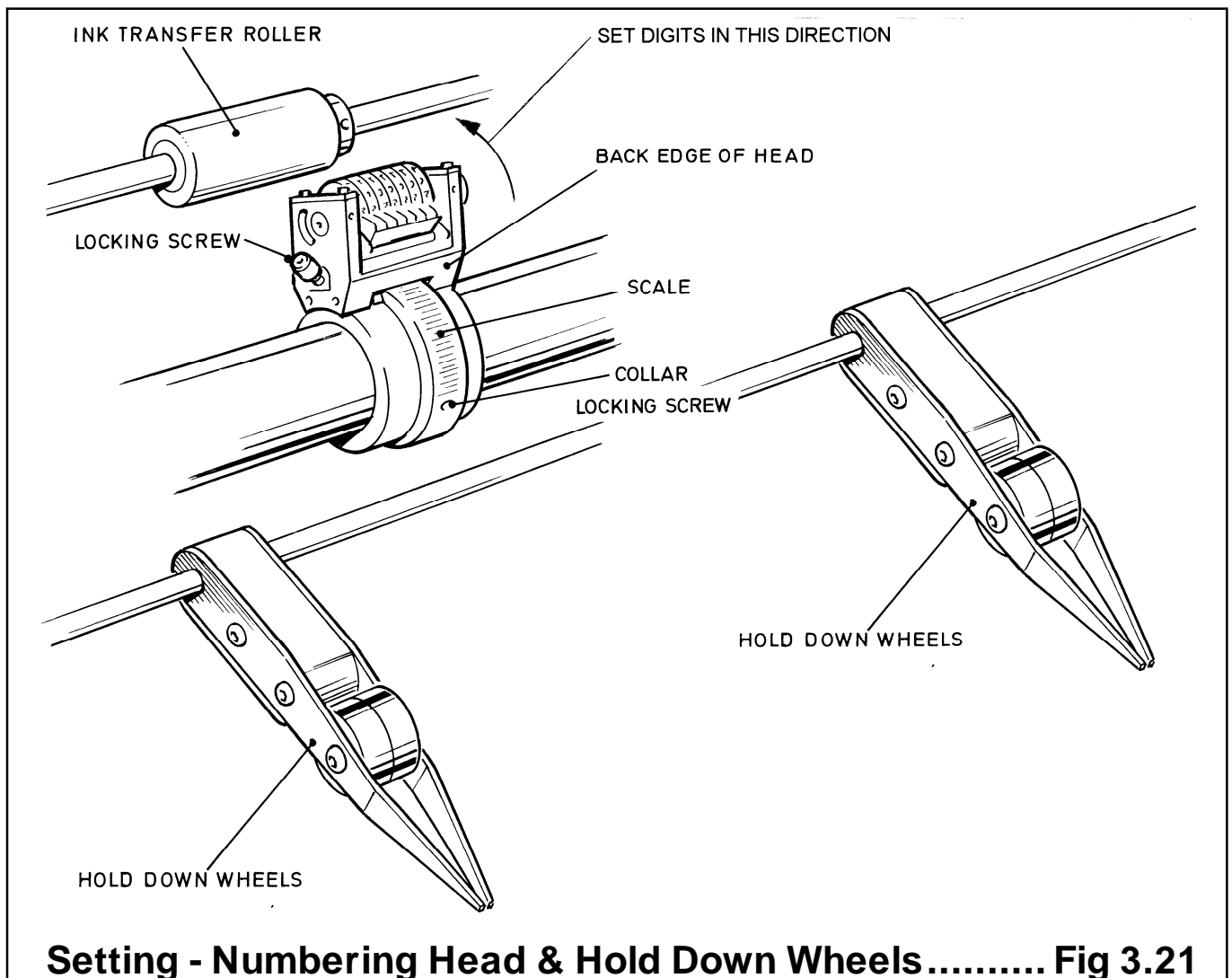

### 3.5 .....Advance cam

Set the advance cam to operate the numbering head as shown in Fig. 3.51. Always operate the auto/man switch & rotate the machine by hand until the numbering head is just past the cam for setting. Position the sheet smoothers/strippers, to hold the work flat, through the exit guard (see Fig 3.51).

#### WARNING

**NEVER OPERATE THE MACHINE UNDER POWER UNTIL THE AUTO/MAN SWITCH HAS BEEN RELEASED, AND THE NUMBERING HEAD HAS BEEN TURNED ONE COMPLETE REVOLUTION BY HAND, TO ENSURE THAT THE HOLD-DOWN WHEELS AND ADVANCE CAMS ARE POSITIONED CORRECTLY.**

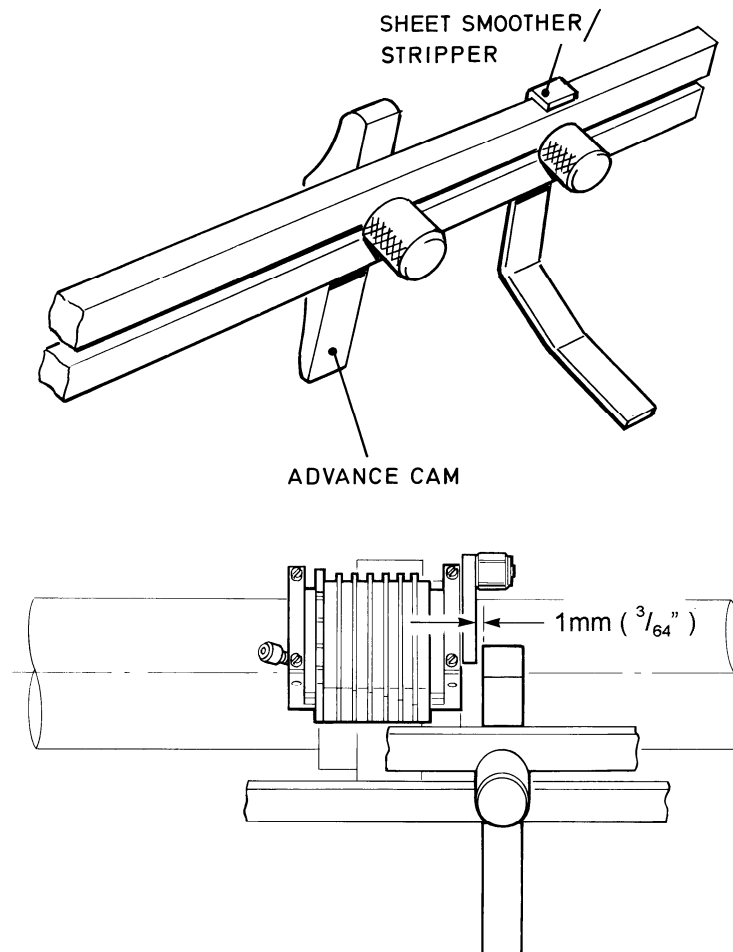

Setting - Advance Cam ..... Fig 3.51

3.6 ..... Stacker

The Stacker Side Guides should be set to guide the sheets into a neat pile. They are magnetic and are simply placed where required but it is important to ensure that they do not come into contact with the sheets before the sheets are free of the output shafts as this may impair registration, particularly when perforating.

Adjust the Back Stop to allow the sheets to drop into the Stacker by releasing its locking knob and sliding it into the required position.

For long sheets, remove the Back Stop by fully unscrewing it's locking knob and manoeuvring it out of it's slot. The Extensions may now be extended to the required position after releasing their locking knobs, which you will find under the Stacker Bed.

The sheet smoother may now be inserted into the centre slot in the output guard. If two smoothers are required they should be inserted into the outer slots. ( If perforating or slitting, see notes in sections 5 & 8 ). Only use smoothers if sheets won't stack without them.

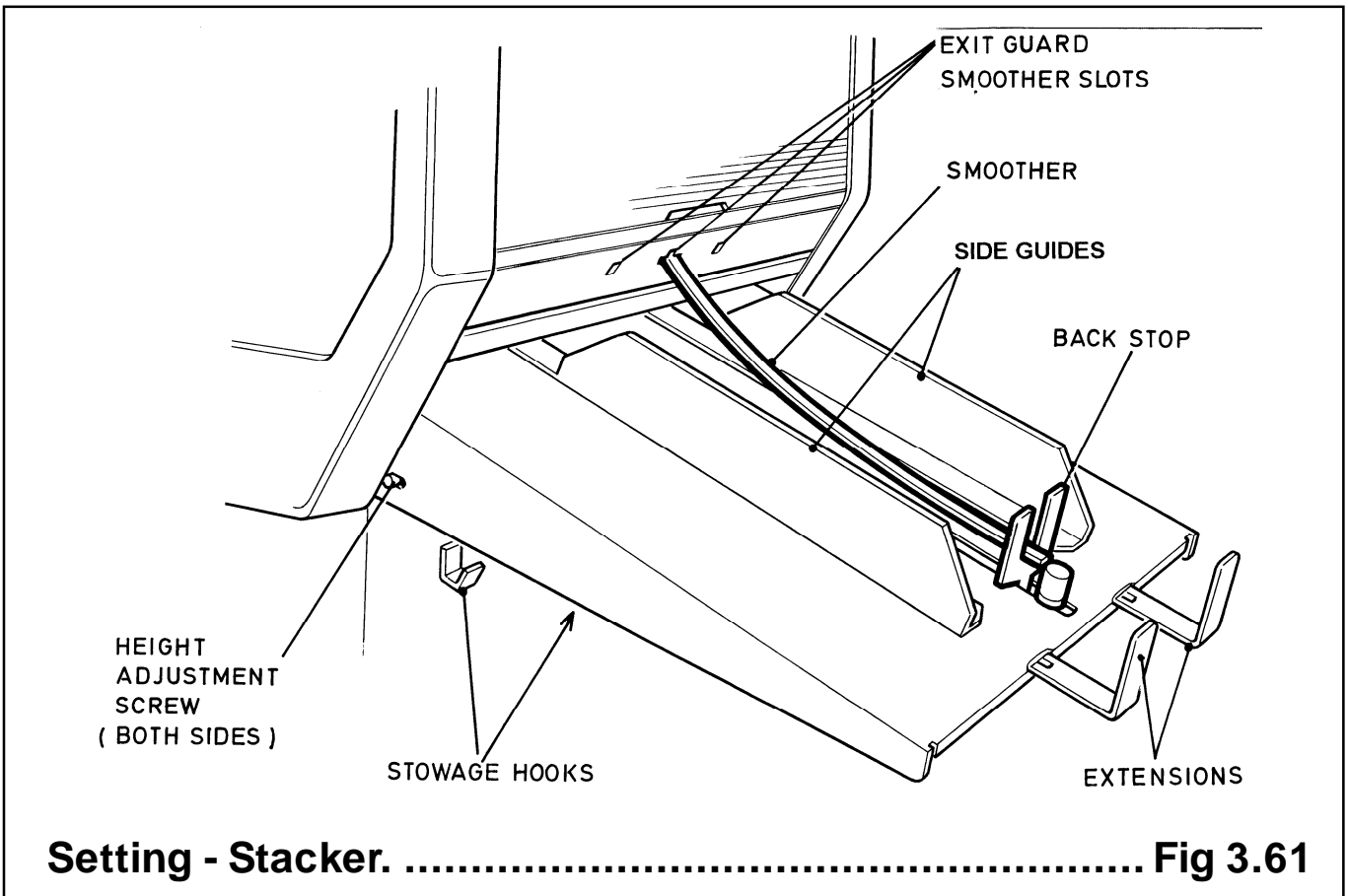

## 4.1 ..... Setting

Set the Ink Transfer Roller so that it runs fully over the numbering head, by releasing it's locking screw with a 2mm Allen key.

Set the Inking Pod position by releasing it's thumb screw and positioning it so that it inks up the Transfer Roller, in the area above the numbering head.

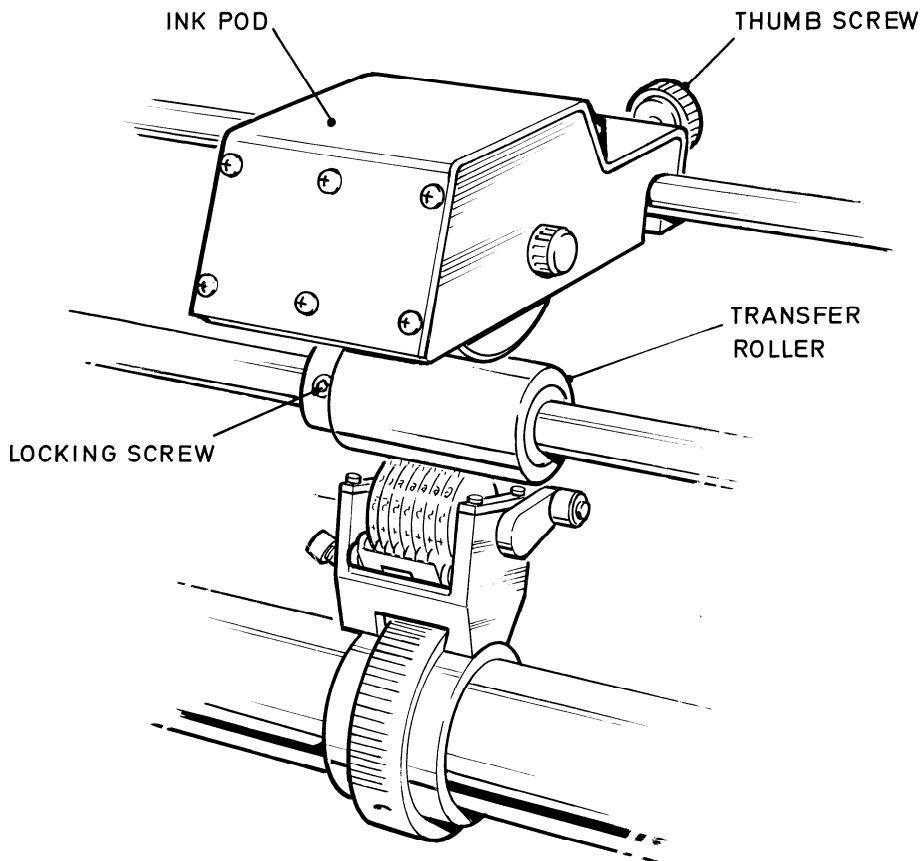

Setting - Inking ..... Fig 4.11

## 4.2 ..... Fitting Ink Roller to Pod

The Inking Pod Assembly may be removed from the machine by removing the locking thumb screw and lifting the Pod off the shaft.

There are two types of Ink Roller available, the standard preloaded type and a re-inkable type. The Ink Roller may be replaced by removing the ink roller screw, (see Fig 4.21) using a 4mm Allen key.

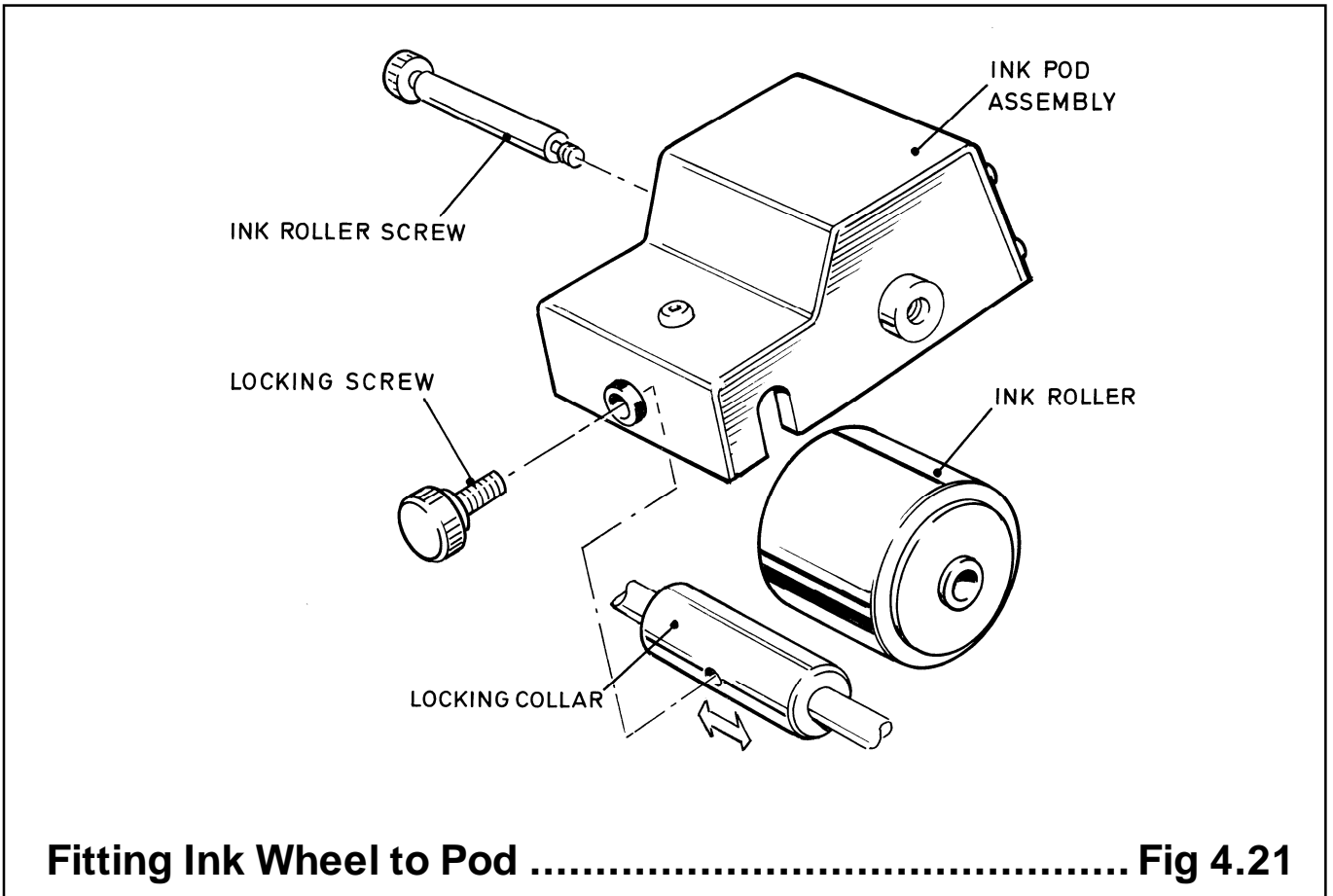

### 4.3 ..... Re-fitting the Inking Pod

To re-fit the Inking Pod Assembly to the machine, slot it over the locking collar and rotate the collar until the screw hole is visible through the hole in the Ink Pod. Fit the locking screw and tighten.

When not in use, the Inking Pod Assemblies may be supported on the sides of the machine. Re-inkable rollers **MUST ALWAYS** be stored at the side when not in use, to prevent a flat spot occurring on the roller. (see 4.4 on page 16)

The ink used in the pre-loaded ink rollers will not dry out when not in use and therefore does not need special storage requirements.

**NOTE..... Do not attempt to re-ink preloaded ink rollers**

Re-inkable rollers will dry out and harden if not used regularly. If drying out or hardening occurs, renew the Ink Roller.

#### **4.4 .....Re-Inkable roller**

The inking system may be fitted with an optional Re-Inkable Roller which if inked using the red and black inks developed for the purpose, can give excellent results.

**NOTE.....** Only use ink which has been supplied by your dealer specifically for this system The ink formulation has been carefully balanced to ensure optimum liquidity coupled with a fast absorption capacity to ensure that it does not dry out too quickly on the roller but does dry quickly once in contact with the paper.

The following procedure should be used for loading the roller with ink:

1. Squeeze 5 ml (a teaspoonful) ribbon of ink from the 30ml tube of ink supplied, on to a metal plate. The plate should be at least 300mm (12" ) long.
2. Install the roller into the inking pod (see section 4.2) and, holding the pod firmly, roll the assembly over the ink from one end of the plate to the other, as many times as necessary to ensure that the ink is evenly distributed over the entire circumference and width of the roller.
3. Allow the roller to stand for at least 8 hours (the pod may be turned upside down and placed on a convenient non-slip surface or installed on to the machine and stacked against the sideframe) to allow the ink to penetrate the surface of the cover and then re-ink the roller carrying out the procedure described above. Less ink will be required this time.

Our tests have shown that approximately two hours of continuous use can be achieved before re-inking becomes necessary and that after subsequent re-filling longer time spans can be achieved. This would indicate that the full capacity of the roller may not be reached until several re-inking cycles have been carried out .

After running the inking system it is important that the pod is lifted clear of the transfer roller and stacked on its stowage points against the machine sideframe or removed from the machine and placed upside down on a non-slip surface. If the roller is left in contact with the transfer roller or left resting upon any other surface, a flat may develop which will impair its efficiency and make it noisy when running.

**NOTE.....** This re-inkable system is only recommended if you use the machine frequently as the roller dries out and solidifies making it impossible to re-ink if it is left without inking for more than a week (depending on temperature).

## 4.5 ..... Secondary Inking Position

There are two positions for the inking assembly as shown in Fig.4.51. The Primary Position is preferred because it allows better access into the machine.

Both positions work equally as well but with the following exceptions:-

- If, after setting a numbering head, it stops below or just in front of the ink transfer roller, you must change the inking to the alternative position. Refer to Figs 4.52 & 4.53 to establish the exact point at which the position will need to be changed.

Failure to move the inking will cause the transfer roller to be damaged (when the head stops below the roller), or poor quality inking (when the head stops just before the roller).

To change from Primary to Secondary Positions or vice versa, remove all Ink Pods, (see section 4.2) push the assembly to the desired position, and then replace the Ink Pods. (See section 4.3)

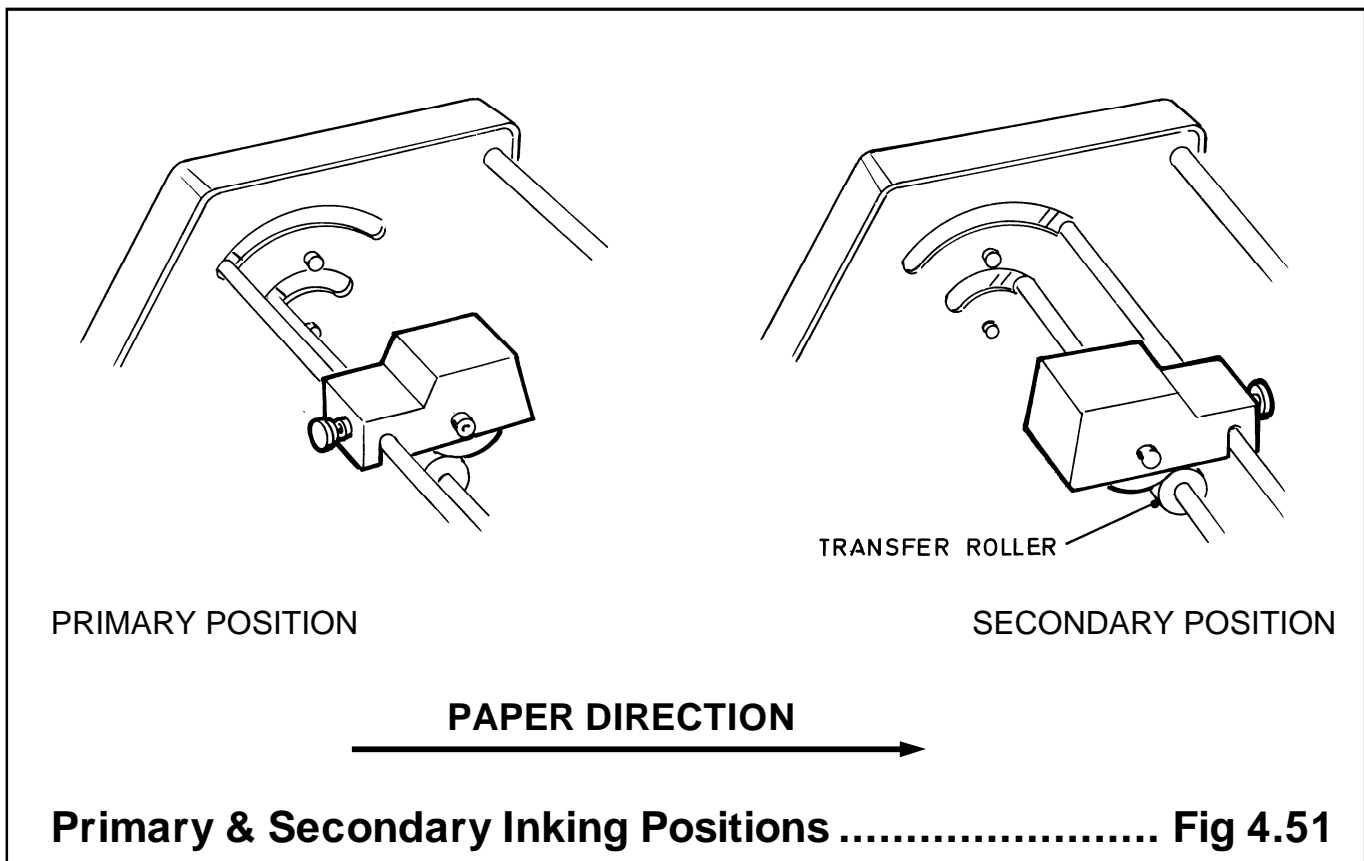

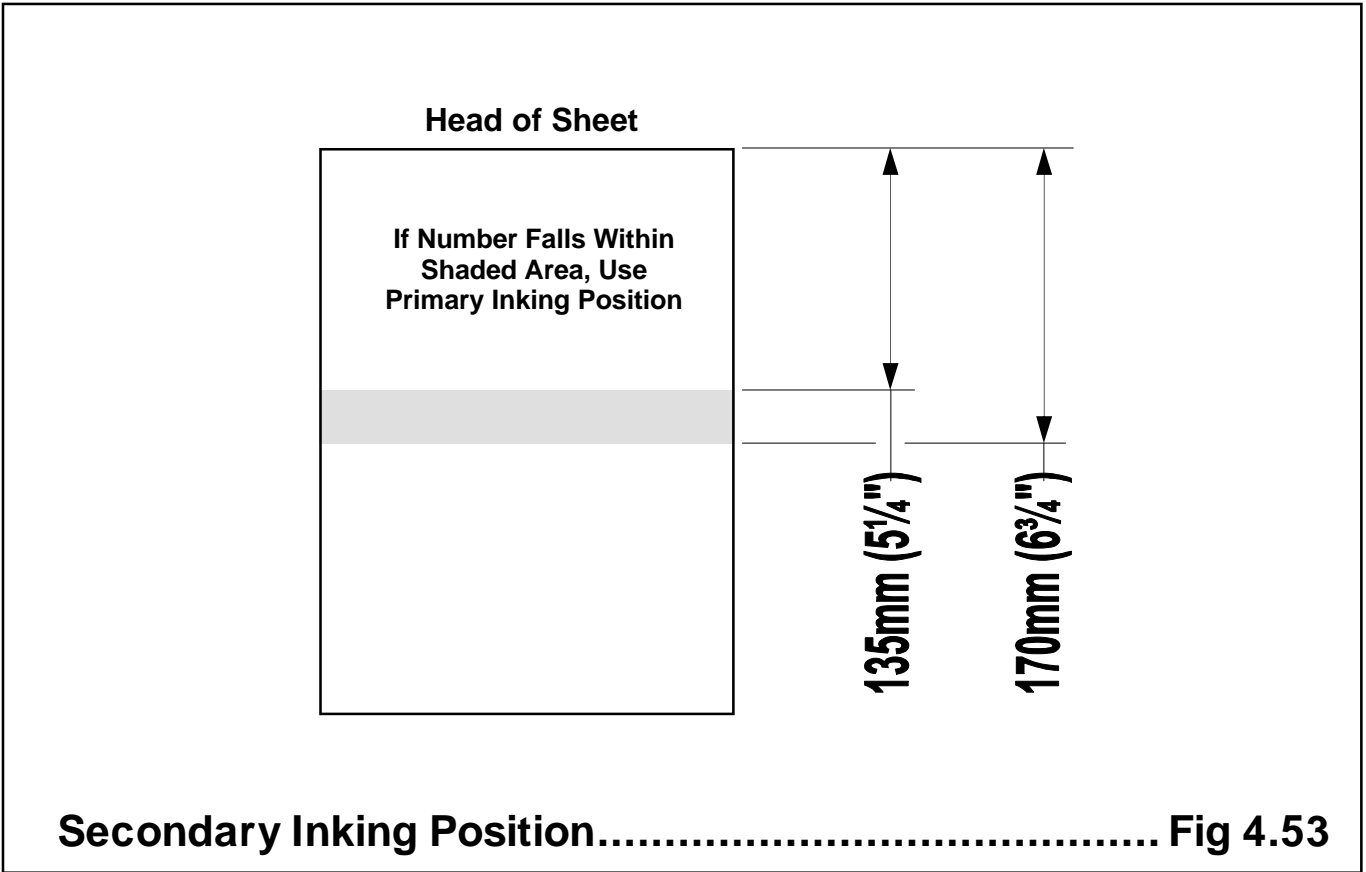
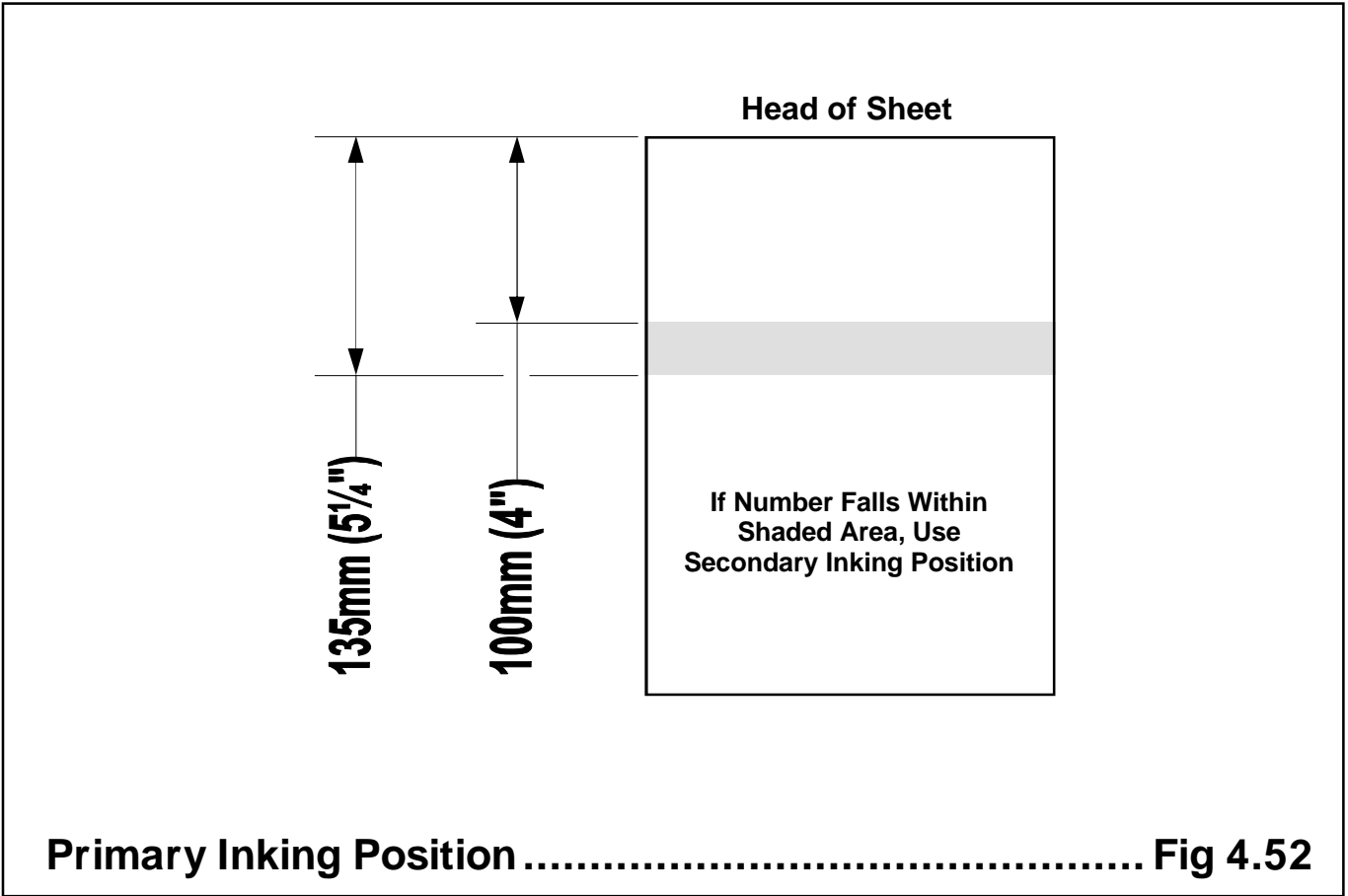

## **5.1 .....Make ready**

Having set the hold-down wheels (see note 2 below) and inking, check the numbering position by switching on the system and operating the feed switch, so that a sheet feeds through the machine. (Remember to turn head by hand BEFORE switching on).

Set the stacker side-guides, back-stop and sheet smoothers (See Fig. 3.61 and note 2 below).

If the first sheet does not print, try a second. If it still does not print, check the platen pressure. (See section 2.2)

With one sheet numbered, it can then be seen if further adjustment is required to the numbering head.

For sideways adjustment, operate the auto/man switch, rotate the machine by hand and release the collar locking screw. Move the collar as required and fully tighten the screw. For vertical adjustment, use the print position control (See section 2.2).

**NOTE 1 ...**Everytime the collars are moved, check that the numbering head will not hit the hold-down wheels or advance cams, by operating the auto/man switch and rotating the machine by hand.

**NOTE 2 ...**If you are intending to use the Perforating & Slitting facility, it is important that particular attention is paid to setting the Hold Down Wheels, Stacker Side Guides and Sheet Smoothers. Any interference with the sheet whilst it is running through the Perforating or Slitting Blades is likely to have an adverse effect upon cutting accuracy. Hold Down Wheels must be set on, or equally about, the centre of the sheet and Side Guides should not touch the sheets. You may need to experiment with the angle of the Stacker Bed, (see section 1.3), and the position of the Smoothers to obtain optimum results. Avoid using Smoothers if possible.

## 6.1 ..... Technical Specifications

Overall Length	Working	900mm	35½"
	Stored	500mm	20"
Width		780mm	31"
Height		1100mm	43½"
Weight		95Kgs	209lbs
Power Requirements		230v-50Hz	
Maximum Running Speed		5100 SPH	
Maximum Number of Heads		4	
Maximum Recommended Sheet Size	Length	460mm	18"
	Width	435mm	17"
Minimum Recommended Sheet Size	Length	210mm	8¼"
	Width	125mm	5"
Recommended Stock Thickness	Maximum	5 Part Carbonless	5 Part Carbonless
	Minimum	45 gsm	11lbs
Maximum Spacing of Heads on same Collar with First Number Printed on head of Sheet.	Parallel	365mm	14-3/8"
	Convex	354mm	13-13/16"
Minimum Spacing of Heads on Same Collar. (Radial Spacing)	Parallel	50mm	1-15/16"
	Convex	73,5mm	2-7/8"
Minimum Spacing of Adjacent Heads	Parallel	62mm	2-3/8"
	Convex	48mm	1-7/8"

Consult Your Agent for Advice Regarding Applications Outside the Recommended Specifications.

The Manufacturer Reserves the Right to Alter Specifications Without Prior Notice

## 6.2 ..... Spacing of Numbers

Although you can position one number anywhere on a sheet within the above specification, there are some restrictions on how close a second number can be placed to the first.

The following diagram shows the minimum and maximum spacings for numbers placed on the same sheet in a single pass.

You can of course, run a sheet through the machine as many times as is necessary, or in a different. direction or orientation

### Convex Boxes .....

### ..... Parallel boxes

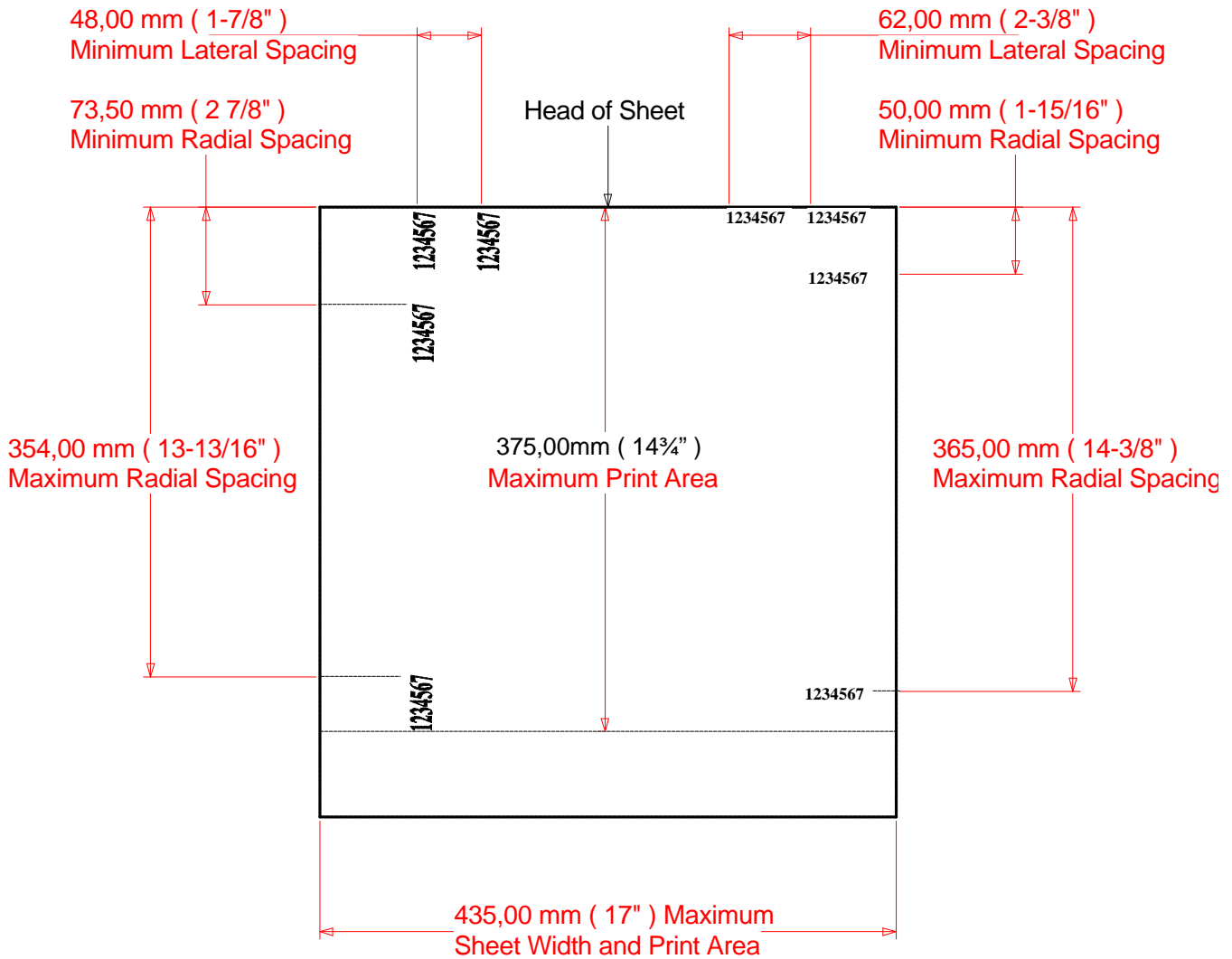

Number Spacing ..... Fig 6.21

### 6.3 ..... Sheet Sizes and Perforation Spacing

The following diagram shows the Maximum and Minimum sheet sizes, the actual printable area for sheets over 375mm (14¾") long, and the Minimum spacings and edge distances for Perforating & Slitting.

It is quite possible to print right up to the edges of sheets which fall within the maximum print area shown, but in order to maintain accuracy Perforations should always be kept well away from the edge of the sheet and certainly no closer than the recommended minimum shown.

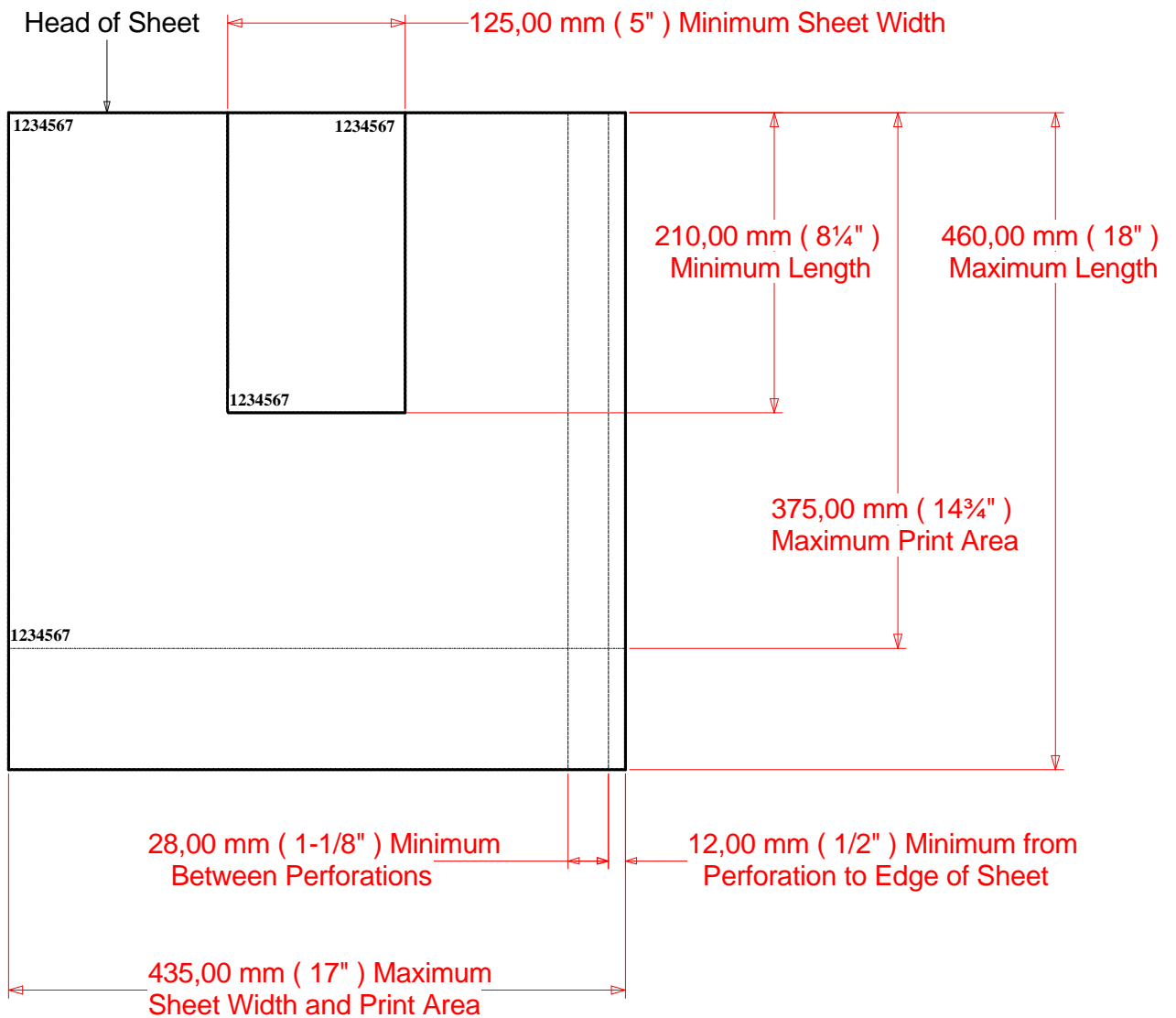

Sheet Sizes & Perforation Spacing ..... Fig 6.31

## 7.1 .....Fitting the Perforators.

Perforating is carried out on the output shafts, access to which is improved by removing the stacker & lowering the exit guard.

The perforating blades are split into two matching halves and are fitted to the upper hubs on the output shafts, as shown in Figs. 7.11 & 7.12 using the four screws supplied.

A hardened anvil is fitted to the lower hub, as shown in Figs. 7.11 & 7.12 using the four screws supplied. The anvils are also made from matching halves.

When fitting the anvils or blades, ensure that the 'vee' formed at the joint of the two halves is facing the hub.

**IMPORTANT** - To prevent blades or anvils chipping, always hold both halves together **CAREFULLY** with one hand and then tighten all four screws using the 2.5mm key provided.

**NOTE** ..... Do not mix matching halves of perforating blades, anvils, or slitting blades.(See section 8 for Slitting details).

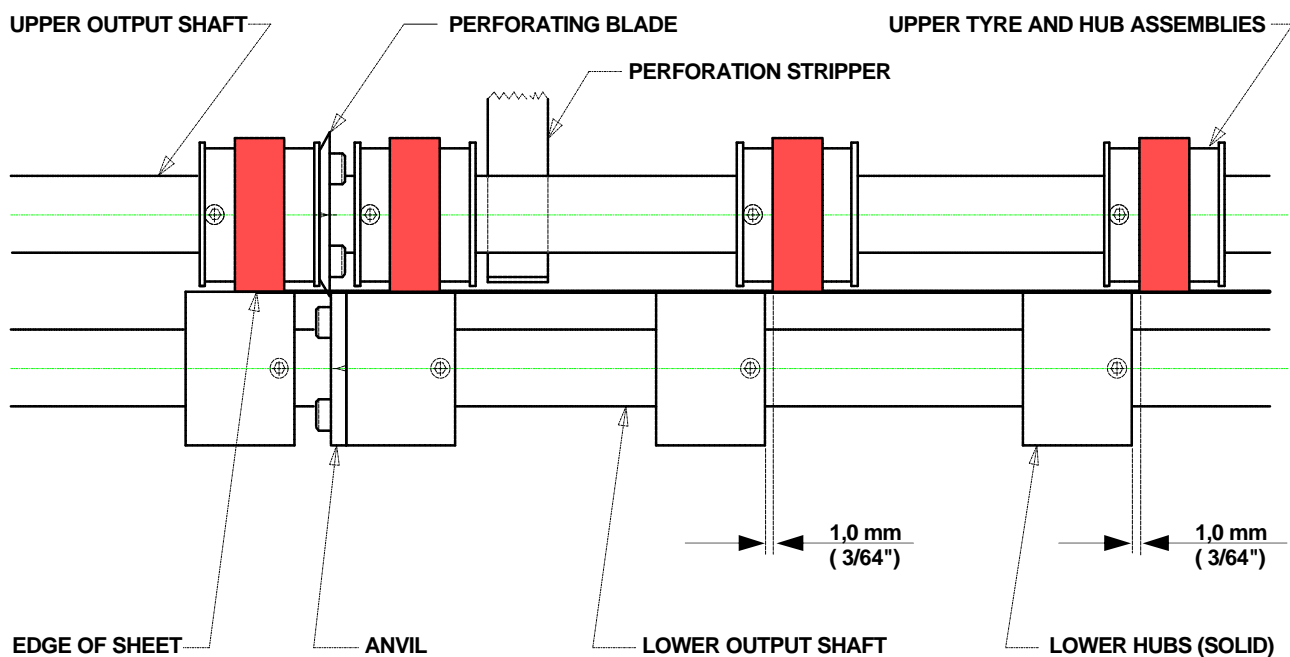

Perforating - Single sheets..... Fig 7.11

## 7.2 ..... Setting up

To set a perforator in the required position, follow these steps:-

- Set up the feed bed as described previously in section 3.1.
- Loosen the hub with the perforating blade fitted and all other hubs on the shaft.
- Wind a sheet through the machine until the sheet is near the blade.
- Tighten the hub with the blade in the exact position to the job.
- Wind the sheet out of the machine and set the stacker guides and backstop. ( see section 3.6 on page 13 )
- Set all the other hubs as shown in the drawings,(Figs 7.11 & 7.12) noting the gaps between upper tyres and lower hubs. **THIS SETTING IS IMPORTANT** to ensure perforating accuracy.
- Fit a perforation stripper as close as possible to the perforating blade (as shown in Figs. 7.11 & 7.12.) This will prevent the sheets wrapping around the blade. See section 8.1 (Slitting) for an important note about setting stacker guides & sheet smoothers.

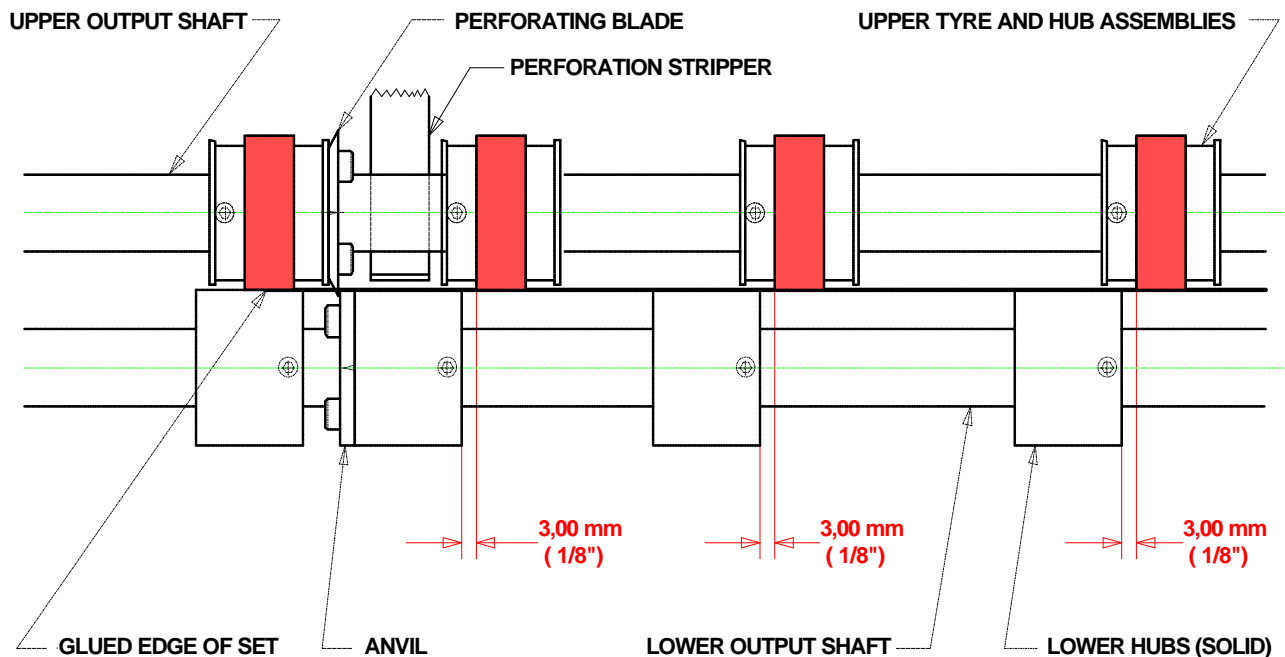

Perforating - Carbonless Sets ..... Fig 7.12

8.1 .....Slitting

Slitting is carried out on the output shafts and is very similar in operation to Perforating as described in the previous section.( 7 )

As with the Perforators the Slitting Blades are split into two matching halves, (which should not be mixed) but in this case they are fitted to both the upper and lower output shafts, using the screws supplied, as shown in fig. 8.11. An Anvil is not required.

When fitting and setting Slitters, refer to Fig 8.11 below and the instructions for Perforating in section 7, starting on page 24.

**NOTE .....** Having setup for Perforating or Slitting it is important that the Hold Down Wheels, Stacker Guides, and Sheet Smoothers are correctly set. If you experience any straightness or alignment problems, check that the Hold Down Wheels are positioned on, or equally about the centre of the sheet, Stacker Guides are not touching the sheet and that the Smoothers are not steering the sheet before it is clear of the output shafts.

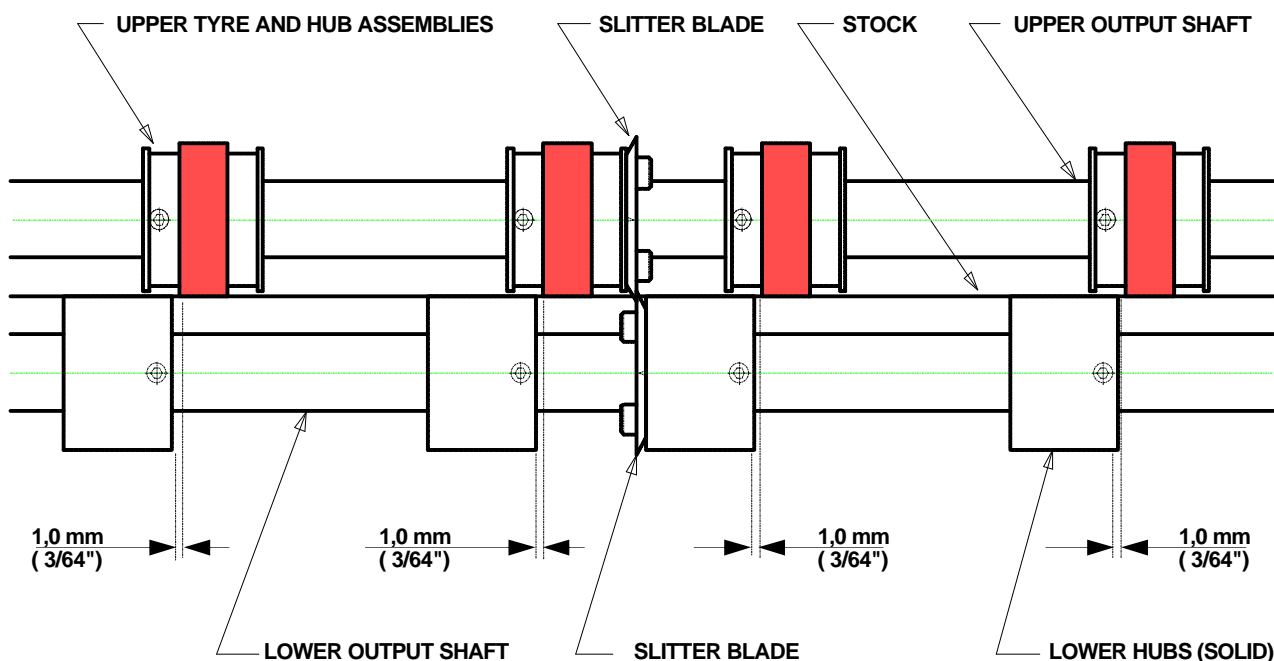

Slitting ..... Fig 8.11

### 9.1 ..... Scoring

Scoring is also carried out on the output shafts.

The Scoring wheel is split into two halves and is fitted to the upper output shaft.

Set up the feeder and wind a single sheet through the machine. As it approaches the output shafts, the Scorer should be positioned so that it aligns with the required position on the job.

Continue to wind the sheet through the machine and then move the lower hubs up to, but not touching, the Scorer blade as shown in Fig. 9.11

The actual spacing between the lower hubs and the Scorer blade is critical and may require some experimentation to obtain a satisfactory Score line.

Move the other hubs as shown in Fig. 9.11

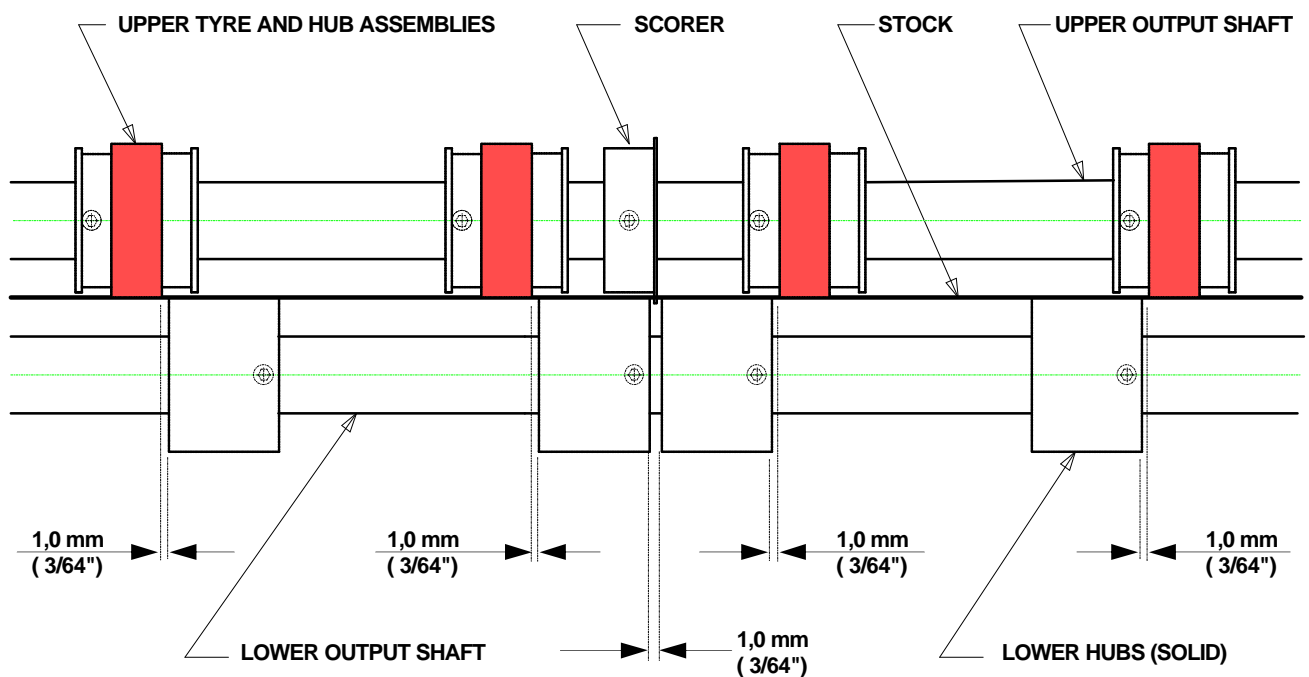

Scoring ..... Fig 9.11

## 10.1 .....Paper Jams

It is not normally possible to rotate the machine backwards. However in order to assist in the removal of paper jams, this can be achieved by releasing the drive system using a 2.5mm allen key to remove the grub screw behind the handwheel.

The input rollers, output shafts or platen may then be rotated in reverse by turning them by hand.

**NOTE.....**The Main Print Shaft cannot be reversed. Attempting to do so will damage the Clutch and impair registration.

After removing the paper jam, align the grub screw holes as follows:-

- Insert the allen key into one of the holes in the collar to prevent it from turning and turn the handwheel clockwise.
- When the key engages with the shaft and drops further into the collar, stop turning, replace the grub screw and tighten **SECURELY**.

**NOTE.....**Do not attempt to clear a jam by cutting the paper as damage to the rollers or platen is inevitable.

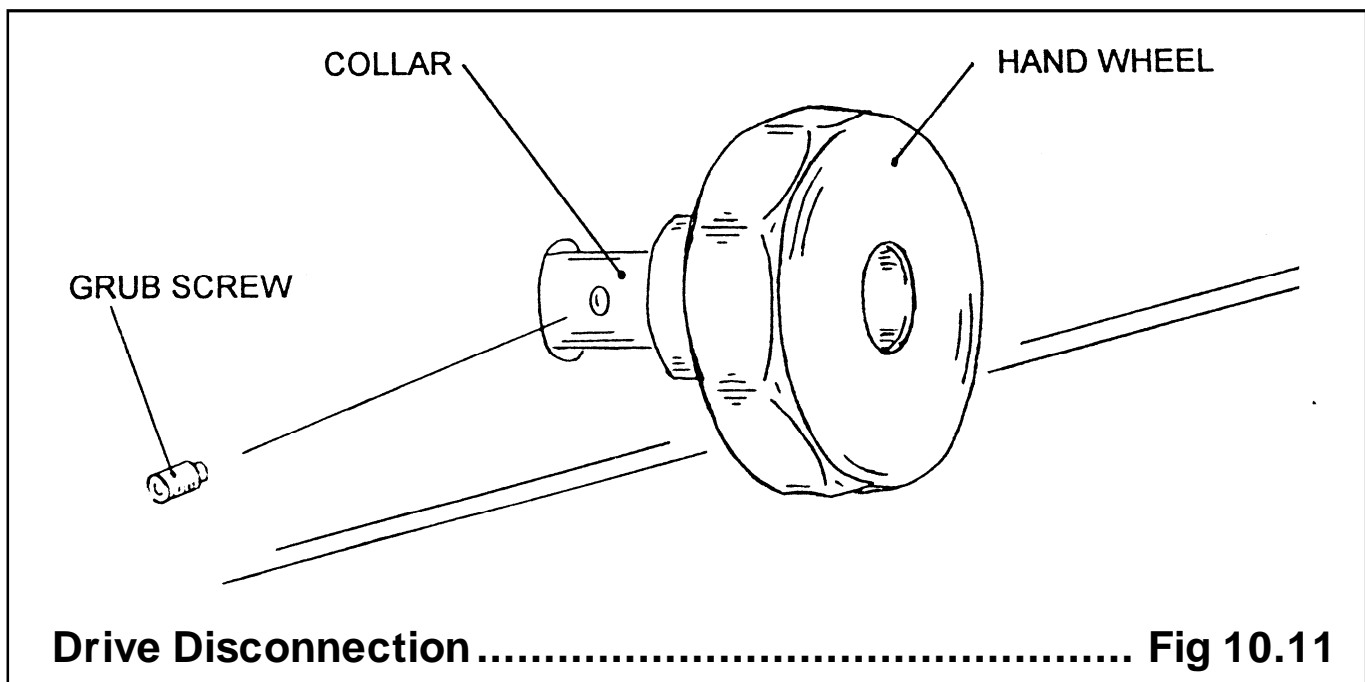

## 10.2 .... Sensor

After a period of use, the sheet sensor may become dirty and the machine will fail to number, causing the sheets to feed continuously.

The sensor can be accessed by removing the screw in the upper sensor mounting, using a 2.5mm allen key. The mounting can then be lifted away, giving access to both upper and lower sensors.

**NOTE .....** Take care not to damage the sensor cable.

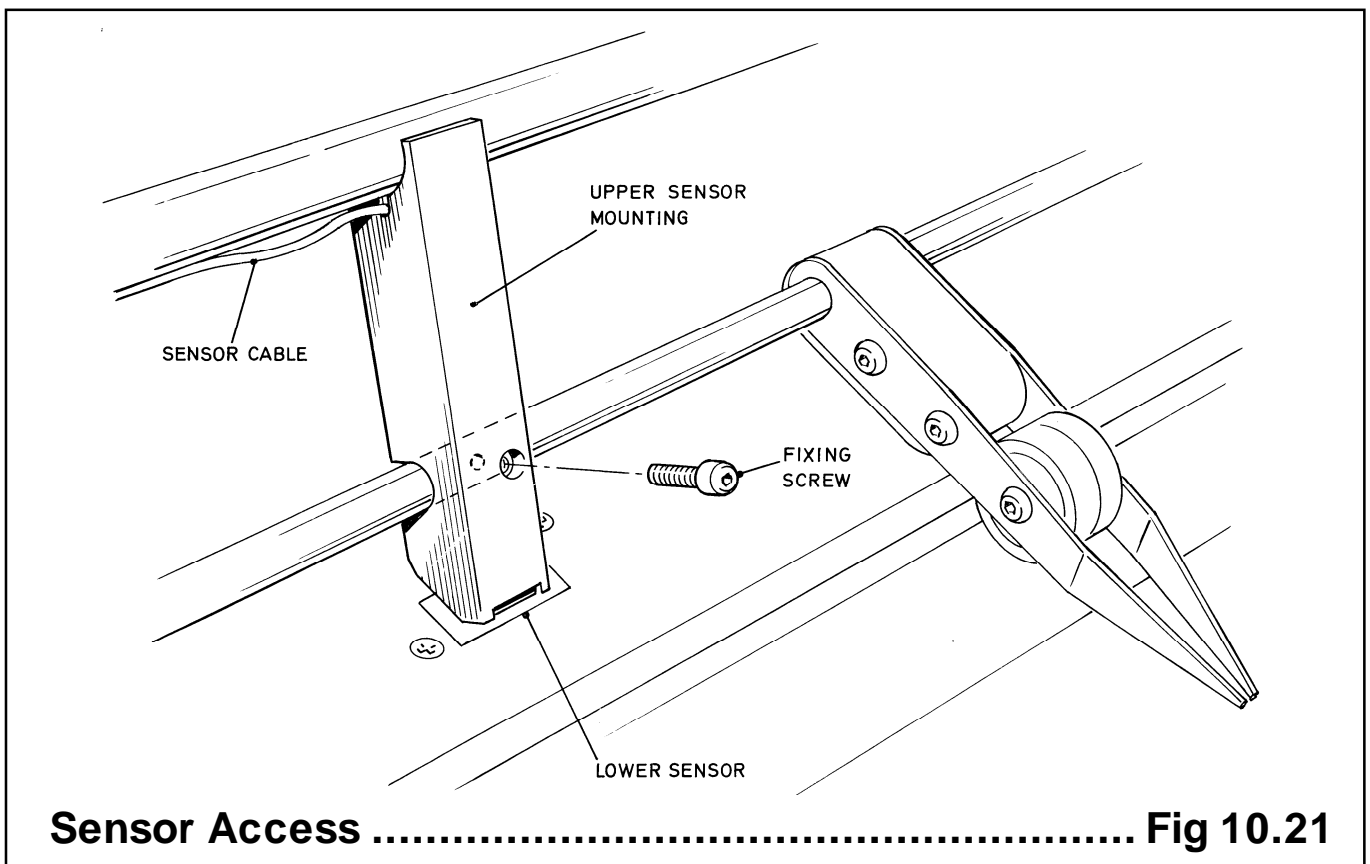

## 10.3 .... Transfer Rollers

The Ink Transfer Rollers, see Fig. 4.11, should be cleaned regularly, using white spirit or a turpentine substitute. This is particularly important if you are using re-inkable ink rollers.

## **10.4 ....Numbering Head**

Numbering Heads are precision instruments and should be handled carefully to avoid damage.

The quality of the paper being numbered, and the type of ink used, all have a bearing on the reliability of the heads performance.

Fluffy paper will clog the head quickly and lead to various faults, including jamming of the number wheels which may necessitate dismantling of the head. ( See Section 10.5 ).

If your machine is fitted with re-inkable rollers, thick or sticky inks, or excessively applied thin inks, will have a similar effect, so care should be exercised when re inking.

**NOTE..... Do not attempt to re-ink standard ink rollers.**

The numbering heads should be regularly cleaned and lubricated, preferably by following the head manufacturers cleaning and lubrication instructions. If these are not available the following guide-lines may be followed.

The complete numbering head may be soaked in a bath of white spirit, with two or three drops of light machine oil added.

After soaking, a small brush may be used to remove ink from crevices. Dry the head using a lint-free cloth.

When the head is completely dry lubricate all moving parts, including the operating arm and its ball or roller and between the number wheels, sparingly with a light machine oil (SAE 30) taking great care not to get oil on the numbering faces.

**NOTE..... Do not use aerosol lubricants as they are normally too thin and very difficult to apply precisely.**

**WARNING**

**NEVER FIT NUMBERING HEADS FROM A PRESS OR ANOTHER MANUFACTURERS NUMBERING MACHINE AS SERIOUS DAMAGE WILL RESULT. YOUR MACHINE REQUIRES HEADS DESIGNED TO RUN ON AN OPERATING CIRCUMFERENCE OF 16.697"**

**10.5 .....Numbering Head - Dismantling**

It may be necessary to dismantle the Numbering Heads from time to time in order to clean them thoroughly or to replace the wheels to allow skip or repeat numbering.

The following instructions are provided as a guide only and are specifically for 60 & 70 series heads. As mentioned earlier, Numbering Heads are precision instruments and should be handled carefully.

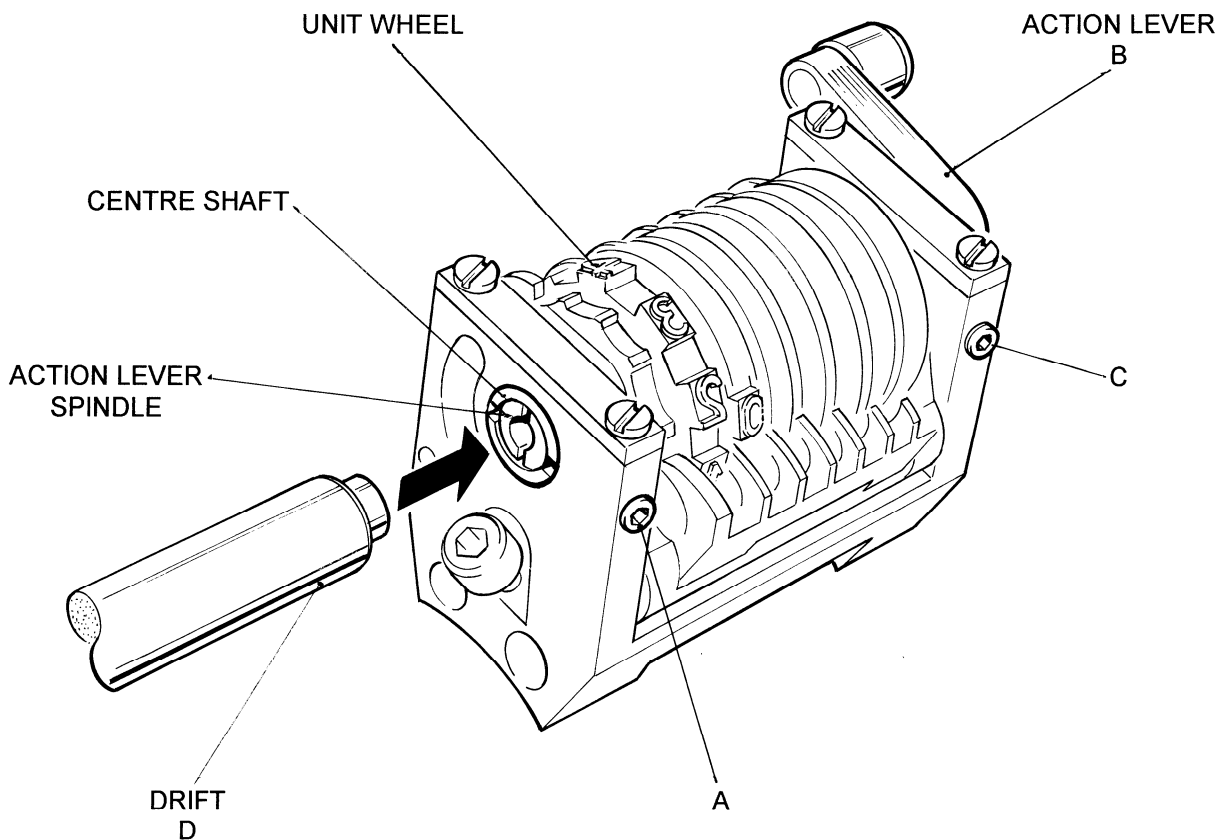

**Dismantling the Numbering Head..... Fig 10.51**

If your machine is fitted with Heads from a different manufacturer or you are unhappy about dismantling them please use the instructions supplied with your heads or consult your dealer.

Repeat or skip numbering is achieved by replacing the standard unit wheel with a special wheel.

Using a 1/16" Allen key, release and unscrew 'A' five full turns. the action lever 'B' may now be worked loose and removed from the head.

Release and unscrew 'C' three full turns, and using a drift 'D' (available as an option under part number 41-001-3) push the centre shaft so that it is protruding 16mm ( 5/8" ) out from the other end of the Head.

The drift may now be withdrawn and the unit wheel lifted clear of the Head.(see Fig 10.52)

**NOTE .....** As you remove the unit wheel, be sure you have a finger over the lower part of the retaining pawl otherwise the tiny spring behind will be lost.

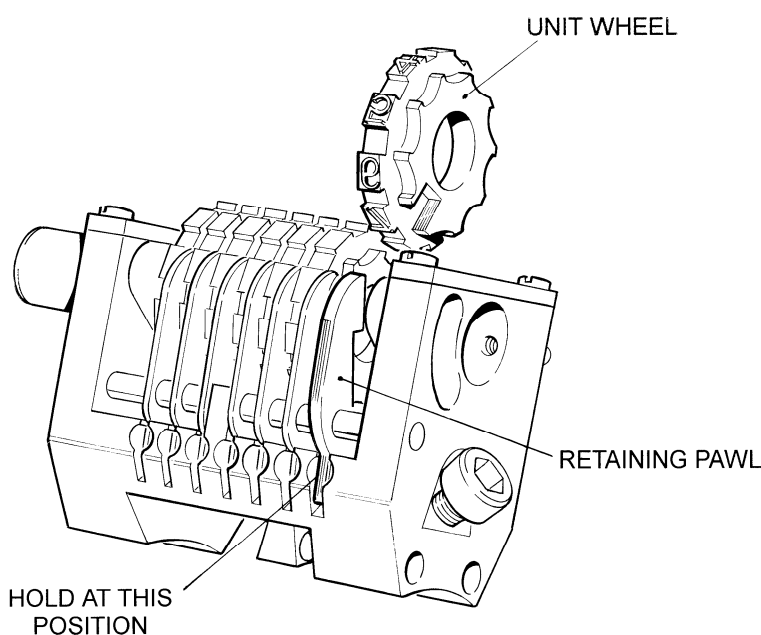

Numbering Wheel Removal..... Fig 10.52

## 10.6 .....Numbering Head - Re-assembly

Fit the appropriate wheel and position it so that the centre shaft can be pushed back into place using the drift. The centre shaft is then aligned so that it's ends are flush and the slots in the ends are horizontal.

Tighten screw 'C' until it is flush with the frame. If it will not go flush, re-align the centre shaft and try again.

Fit the action lever ,ensuring that its operating pin engages in the hole in the actuating pawl bar. Operate the action lever up and down to confirm correct assembly and operation. Now tighten screw 'A' until it is just clear of the end of the action lever spindle.

Engage a screw-driver into the slot in the end of the action lever spindle and rotate clockwise until the slot is vertical. Hold this position whilst fully tightening screw 'A'. If the screw will not go flush, re-align the spindle and try again.

<b>SYMPTOM</b>	<b>CAUSE</b>	<b>REMEDY</b>
Machine Dead & No Lights on Front Panel.	Not Switched On.	Switch Main Isolator On.
	Fuse Blown in Plug.	Replace Fuse.
	Fault in Power Supply.	Check Supply.
	Loose Power Lead.	Check Connection.
System Switch Will Not Latch.	Guard Not Closed.	Ensure Guards are Securely Closed.
	Feed Bed Not Properly Installed.	Ensure Feed Bed is Fully Home.
	System Fuse Fault.	Check Fuse is Intact & that Holder is Secure.
	Defective Switch.	Call Service Agent.
Drive Motor Will Not Run (Switch Latched)	Motor Fuse Fault.	Check Fuse is Intact & that Holder is Secure.
	Paper Jammed in Rollers.	Remove All Paper from Within Machine.
	Feed Switch On with No Paper on Feed Bed.	Switch Feed Off & Load Paper.
	Component Fault.	Call Service Agent.
Machine Will Not Feed.	Feed Nip Wheel Not Set Correctly.	Set Nip Wheel (See 3.1).
	Paper Not Shingled Correctly.	Remove Paper from Feed Bed & Shingle.
	Auto-Reset Not Active.	Switch Isolator Off, Wait 30 seconds, Switch Back On.
Machine Will Not Number.	Auto-Reset Not Active.	Switch Isolator Off, Wait 30 seconds, Switch Back On.
	Dirty Sensors.	Clean Sensors (See 10.2).
	Faulty Component.	Call Service Agent.

<b>SYMPTOM</b>	<b>CAUSE</b>	<b>REMEDY</b>
<b>Number Image Poor.</b>	<p><b>Ink Roller Empty.</b></p> <p><b>Transfer Roller or Inking Pod incorrectly Positioned</b></p> <p><b>Numbering Head Under, or Just in Front of Transfer Roller When Stopped.</b></p> <p><b>Insufficient Platen Pressure.</b></p>	<p><b>Replace Ink Roller.</b></p> <p><b>Re - Position Transfer Roller &amp; Inking Pod.</b></p> <p><b>Move Transfer Roller Assy. to Secondary Inking Position. (See 4.5).</b></p> <p><b>Increase Platen Pressure.</b></p>
<b>Number Image Scuffed</b>	<p><b>Excessive Platen Pressure.</b></p> <p><b>Dirty/Oil Contaminated Head</b></p> <p><b>Mechanical Problem.</b></p>	<p><b>Reduce Platen Pressure.</b></p> <p><b>Clean Faces of Wheels.</b></p> <p><b>Call Service Agent.</b></p>
<b>Number Register Poor</b>	<p><b>Paper Transport Mis-Alignment.</b></p> <p><b>Drive Disconnection Screw Miss-Aligned or not Secure.</b></p> <p><b>Mechanical Problem.</b></p>	<p><b>Check &amp; Reset Side Guides and Hold Down Wheels.</b></p> <p><b>Re-Align and Tighten Grub Screw. ( See Section 10.1 )</b></p> <p><b>Call Service Agent.</b></p>
<b>Numbers Not Indexing</b>	<p><b>Dirty / Dry Numbering Box.</b></p> <p><b>Advance Cam Not Clamped Tightly.</b></p>	<p><b>Clean &amp; lubricate Box.</b></p> <p><b>Tighten Knurled Clamp Knob.</b></p>
<b>Zeros Sinking on Run.</b>	<p><b>Excessive Platen Pressure.</b></p> <p><b>Faulty Numbering Box.</b></p>	<p><b>Reduce Platen Pressure.</b></p> <p><b>Try Another box, Call</b></p>
<b>Perforating Crooked</b>	<p><b>Side Guides Too Loose.</b></p> <p><b>Paper Size Varying.</b></p> <p><b>Feed Nip Wheel Not Set.</b></p> <p><b>Paper Not Shingled Correctly.</b></p> <p><b>Insufficient Sheet Control.</b></p> <p><b>Incorrectly Set Output</b></p> <p><b>Stacker Guides &amp; Smoother</b></p>	<p><b>Re-Set guides.</b></p> <p><b>Trim Paper, Re-Set Guides.</b></p> <p><b>Set Nip Wheel (See 3.1).</b></p> <p><b>Remove Paper from Feed Bed &amp; Shingle.</b></p> <p><b>Re-set Hold-Down Wheels.</b></p> <p><b>Re-Set Output Tyres. (7.1).</b></p> <p><b>Check &amp; Re-set Guides and</b></p>
<b>Sheets Wrap Around Perforating Blades.</b>	<p><b>Sheet Stripper Not Set.</b></p>	<p><b>Fit Sheet Stripper &amp; set Close to Blade.(Fig. 7.11)</b></p>